



mixing consoles

TIMER

**USER/SERVICE
MANUAL**

D&R Electronica Weesp b.v.
rijnkade 15B
1382 GS WEESP, The Netherlands
Phone: ++31 (294) 418-014
Fax: ++31 (294) 416-987
website: www.d-r.nl
E-mail: info@d-r.nl

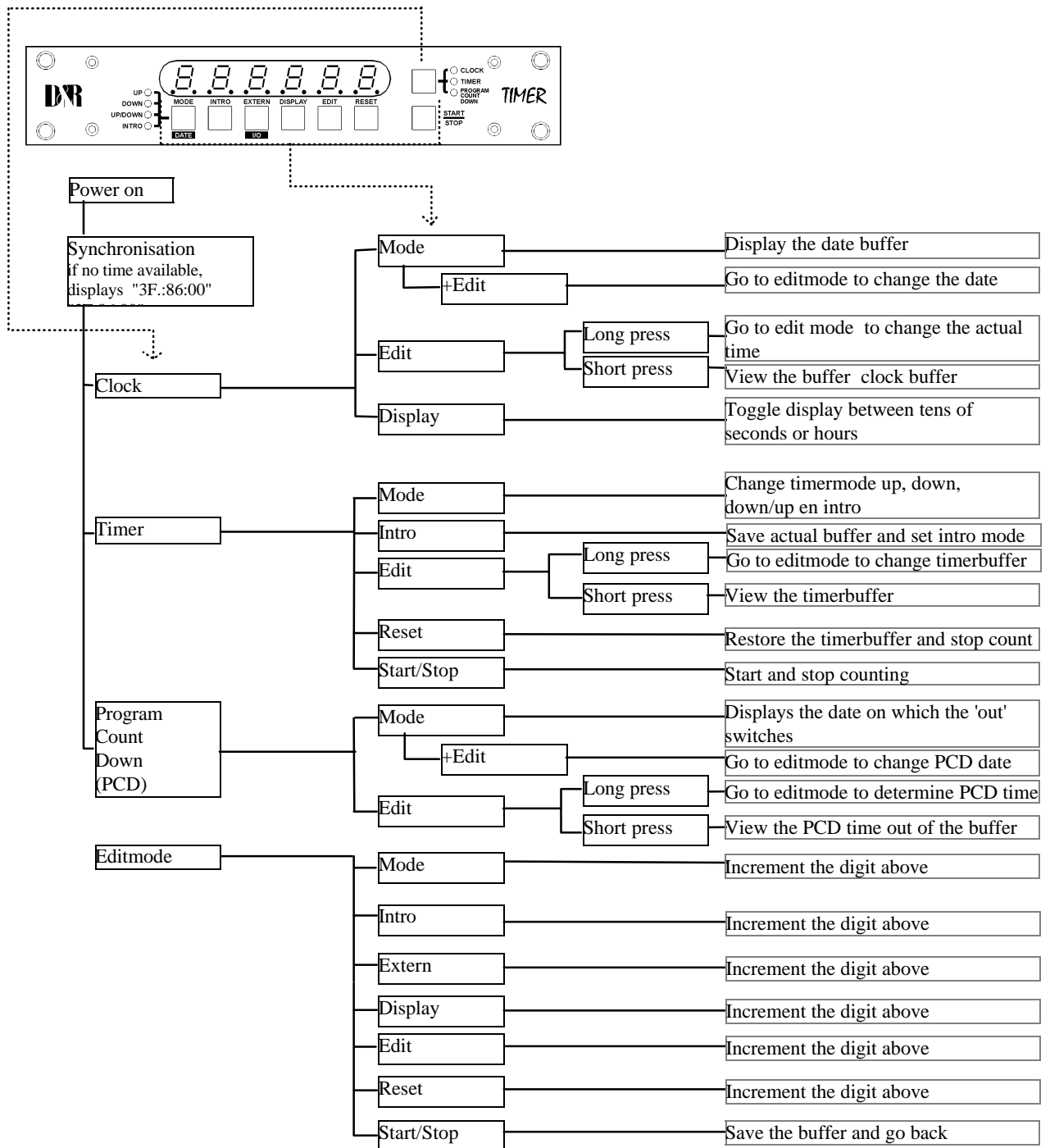

This figure shows a short list of all functions. The boxes in the centre show the keys to change the functions in the active mode. The result of this activity is written in the box on the right side of the page. To toggle between operating modes push the upper-right button. See the other side for a functional description

FUNCTIONAL DESCRIPTION OF TIMER MODULE

The timer may operate in three modes. The clockmode, Timermode and Program-count-down mode (in short called PCD). The upper-right button selects the operating mode.

CLOCK MODE

The first mode is the **Clockmode**. After power-up and synchronising this mode is entered. This mode displays the actual time, when this is not right, you must enter the edit mode by pressing the edit key for about one second. A short push on this key displays the buffer. When the time has been edited you can press the start/stop button as soon as the edited time is actual. Now the timer continues with the new time.

TIMER MODE

The **Timer mode** is the second mode. In this mode you can select several counters for specific timing. You can select this mode by hitting the mode key. The LED's on the front indicate in which mode the timer operates, Count-up, Countdown, Count down/up or Count-intro.

The start value of the timer may be entered by using the edit-function. For the Count-intro. mode a special key is made. When you start the timer (e.g. count-up) and you press the intro-key, the actual bufferstate is grabbed and put into the edit-buffer. With a reset, the edit-buffer is used for restart. The start/stop button is used to start and stop the timer.

In the timermode you can also use the Airmix input. This input receives a faderstart, faderstop and/or a reset. When the signal on the tip is high the timer is active or else it doesn't count. When a pulse is generated on the ring, the buffervalue is stored in the timer. You can easily time intro.'s and jingles during this setup.

PROGRAM COUNT DOWN MODE

The PCD mode acts like the countdown mode. When the counter passes zero, a relay connects the ring and tip of the 'out' jack.

In the editmode you can give an end time (e.g. end of your broadcast). The timer calculates the remaining time. This mode calculates only in minutes and hours, not seconds. This is because all "programs" are ending on full minutes.

DCF INPUT

The DCF-input is used for synchronising the internal clock to an external DCF-clock. This function is optional and only available for use in Northern-Europe. If the data from the external DCF-clock receiver is received properly by the internal circuitry a blinking point shall be seen positioned after the "Sec" indication in a 1 sec sequence.

EDIT FUNCTION

The edit-function acts like a separated mode. For every mode the timer has a buffer. Due to a edit, you can change the edit-buffer for this mode. So in the timermode you don't affect the clock or Program Count Down (PCD) buffer. When you leave the editmode, the buffer is saved and activated. With a short push on the edit button, you can see the actual value of the buffer (of the actual mode).

D&R Electronica Weesp BV, rijnkade 15B, 1382 GS WEESP The Netherlands
Phone ++31 (294) 418-014, Fax +31 (294) 416-987

Installing battery back-up of the Timer

To keep continuously clock information when the timer is disconnected from AC power, a lithium cell-battery needs to be installed.

It needs to be a 3 volt button type cell, for instance a Varta CR 2025 or equivalent.

INSTALLATION

- 1. Remove the unit from the mains**
- 2. Remove the cover by unscrewing the bolts on the left and right side.**
- 3. Insert cell with + upwards**
- 4. Place cover again and mount all sides together.**
- 5. Power up the unit and your timer will hold all its clock information during power down.**

Conformity statement according to ISO/IEC Nr. 22 and EN 45014

Name Manufacturer D&R Electronica Weesp b.v.
Address manufacturer Rijnkade 15B,
1382 GS Weesp,
The Netherlands

declares that this product

Name product TIMER
Modelnumber n.a.
Produktoptions All

passed the following product specifications:

Security EN 60950: 1988 +A1, A2

EMC: CISPR-22: 1985 / EN 55022: 1988 class B (*)
EN 50082-1: 1992
IEC 801-2:1991 / prEN 55024-2:1992 - 3kV CD, 8kV AD
IEC 801-3:1984 / prEN 55024-3:1991 - 3 V/m
IEC 801-4:1988 / prEN 55024-4:1992 - 0.5kV signal cables,
1 kV powercables.

Extra information:

The product passed the specifications of the following regulations;

Low voltage 73 / 23 / EEG
EMC-regulations 89 /336 / EEG.

(*) The product is tested in a normal users environment.

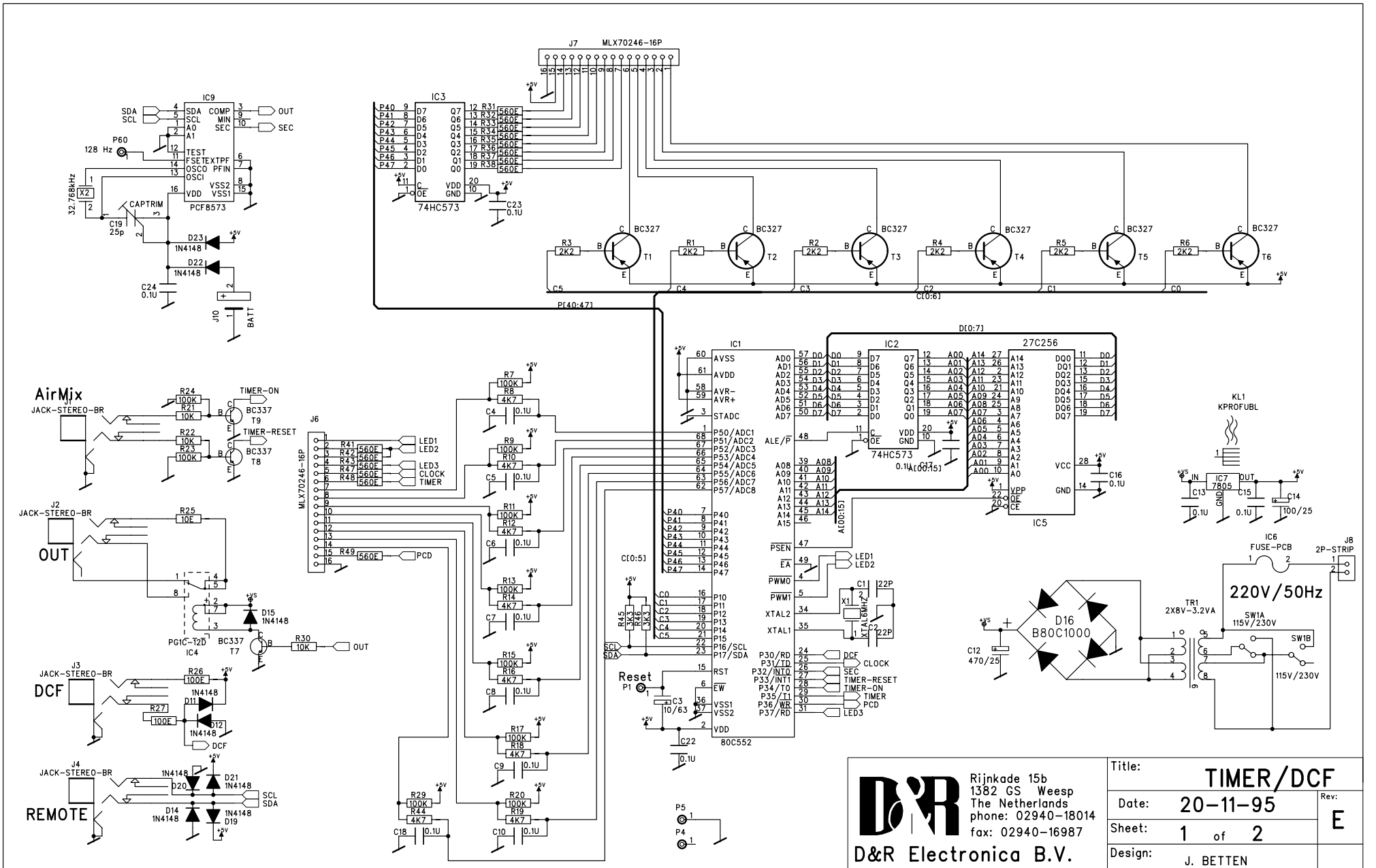

 D&R	Rijnkade 15b 1382 GS Weesp The Netherlands phone: 02940-18014 fax: 02940-16987		Title: TIMER/DCF
	Date: 20-11-95		Rev: E
	Sheet: 1 of 2		Design: J. BETTEN
	Design: J. BETTEN		

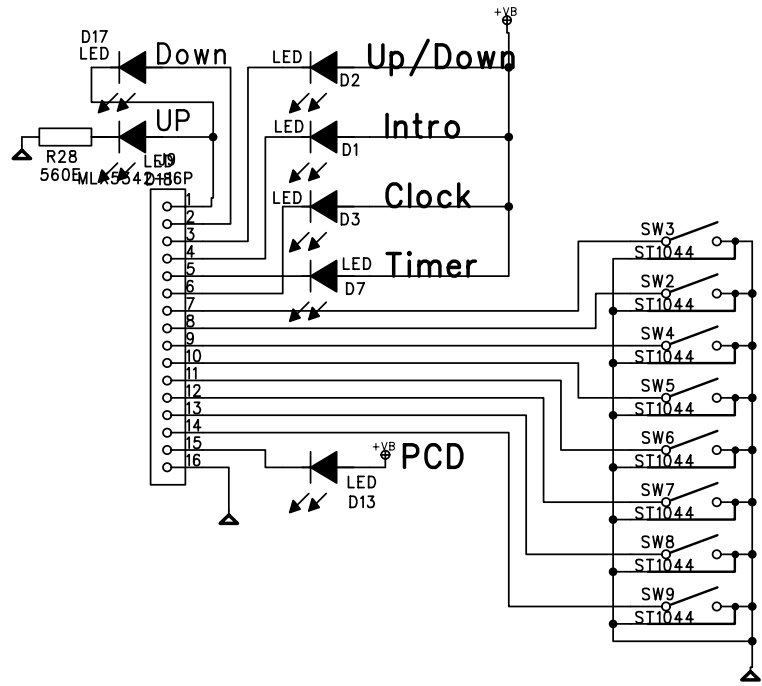
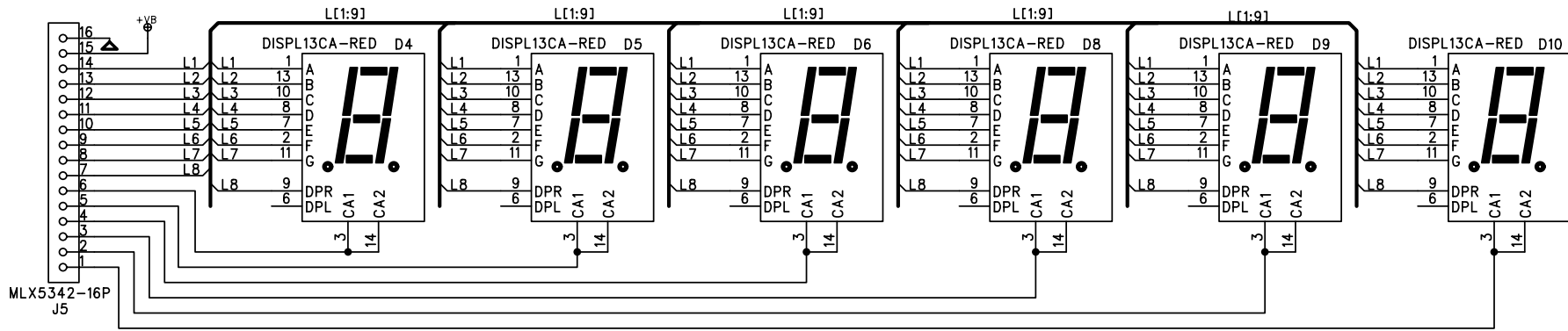

D&R Rijkade 15b
 1382 GS Weesp
 The Netherlands
 phone: 02940-18014
 fax: 02940-16987

D&R Electronica B.V.

Title:	TIMER/DCF	
Date:	03-10-1995	Rev: E
Sheet:	2 of 2	
Design:	J. BETTEN	

B I L L O F M A T E R I A L D & R Electronica Weesp BV (SERVICE-MANUAL)

60898540 Timer 9.5"

Articlecode	Description	Quantity	Unit
.10950470	Batterij 3V (lithium knoopcel)	1.0000	st
.10950471	Batterij houder knoopcel	1.0000	st
.10250345	Brugcel B80C1000 (rond)	1.0000	st
.10400217	Condensator ker 22p R2.5	2.0000	st
.10401241	Condensator ker 100nF/50V R5 T	16.0000	st
.10600180	Connector netaansklem 2p 5mm	1.0000	st
.10250342	Diode 1N4148 (signaal)	9.0000	st
.10400284	Elco 10uF / 40V radiaal R5.0	1.0000	st
.10400292	Elco 100uF / 25V radiaal R5.0	1.0000	st
.10400294	Elco 470uF / 25V radiaal R5.0	1.0000	st
.10600521	Header haaks 16p box (R 2.54)	2.0000	st
.10600520	Header recht 16p box (R 2.54)	2.0000	st
.10250026	Ic 27C512-10 EPROM 64K 100ns	1.0000	st
.10250033	Ic 74HC573 (octal-D latch)	2.0000	st
.10250291	Ic 7805 TO220 SGS (volt.reg)	1.0000	st
.10250036	Ic 80C552 (8-bit micro-comptr)	1.0000	st
.10250200	Ic PCF8573P (clock calendar)	1.0000	st
.10600396	Ic-voet 16 pins (vork-contact)	1.0000	st
.10600398	Ic-voet 20 pins (vork-contact)	2.0000	st
.10600401	Ic-voet 28 pins (vork-contact)	1.0000	st
.10600403	Ic-voet 68 pins (PLCC Socket)	1.0000	st
.10600432	Jack chassis break	4.0000	st
.10700625	Kartelring M 3 (buitenvertan)	1.0000	st
.10720662	Koelprof KL-169/SW TO-220	1.0000	st
.10250397	Kristal 32.768 KHz (1.27)S423	1.0000	st
.10250395	Kristal 6.00 MHz	1.0000	st
.10250120	Led Display 10mm c.anode (red)	6.0000	st
.10700610	Moer M 3	1.0000	st
.10201140	Print Timer 9.5"/e	1.0000	st
.10950584	Printtrafo 3.2VA 2x8v 2x115v	1.0000	st
.10550001	Relais D1C121000 1xchnge minid	1.0000	st
.10550009	Schakelaar ST1044(gr)momentary	2.0000	st
.10550008	Schakelaar ST1044(zw)momentary	6.0000	st
.10700616	Taptite M3x10 bolkopozidr/zw.	1.0000	st
.10250333	Transistor BC-327/25 (pnp)	6.0000	st
.10250332	Transistor BC-337/25 tape(npn)	3.0000	st
.10400320	Trimmer 65 pF (5.5->65pF)	1.0000	st
.10350733	Weerstand 2k2 5% 1/4W	6.0000	st
.10350735	Weerstand 3k3 5% 1/4W	2.0000	st
.10350737	Weerstand 4k7 5% 1/4W	8.0000	st
.10350705	Weerstand 10E 5% 1/4W	1.0000	st
.10350741	Weerstand 10k 5% 1/4W	3.0000	st
.10350717	Weerstand 100E 5% 1/4W	2.0000	st
.10350753	Weerstand 100K 5% 1/4W	10.0000	st
.10350726	Weerstand 560E 5% 1/4W	15.0000	st
.10990693	Zekering 160mA slow 5x20mm	1.0000	st
.10990675	Zekeringhouder print + kap	1.0000	st
10700076	Adereindhuls ong. 0.75mm/L=6	2.0000	st
10650448	Bandkabel 20p (R 1.27)	30.0000	cm
10600466	Connector bandkabel female 16p	4.0000	st
10800924	Doos Randapparatuur 9.5"	1.0000	st
10700975	Dubbelzijdig plakband 12mm dun	20.0000	cm
10101145	Front 9.5" Timer/a	1.0000	st
10500962	Isolatiebus TO-3 NYLON	4.0000	st
10500084	Isolatieplaat 9.5" randapp.PVC	1.0000	st
10600436	Jack moer	4.0000	st
10600007	Kabelschoen + boutgat M3 rood	1.0000	st

10700625	Kartelring M 3 (buitenvertan)		1.0000	st
10150093	Kast 9.5" IHE version D		1.0000	st
10250386	Led 3mm green SLR-03A210-020		3.0000	st
10250387	Led 3mm red SLR-03A510-020		4.0000	st
10700610	Moer M 3		1.0000	st
10600498	Netsnoer 3 aders euroconnector		1.0000	st
10700656	Plakvoet bouton zwart (10x10)		4.0000	st
10100656	Plexiglas Timer		1.0000	st
20851140	Print bestukt Timer		1.0000	st
10800956	Schuimblok 9.5"		2.0000	st
10800429	Sticker CE		1.0000	st
10800275	Sticker OUT/IN		1.0000	st
10800421	Sticker WARNING (rood)		1.0000	st
10700787	Taptite M3x6 bolkop/pozidr/zwrt		1.0000	st
10700790	Taptite M3x6 verzkop/pozidr/zw		8.0000	st
10700788	Taptite M3x8 verzkop/pozidr/zw		8.0000	st
10700691	Trekontlasting voeding rond		1.0000	st