

"ST 1600"

USER MANUAL

DNR



ST 1600 SERIES

INTRODUCTION

The D & R ST 1600 series master recording consoles have been designed to be the most technologically sophisticated, cost-effective, flexible and engineer-oriented production recording console.

The cost-effective part of the console has been realised:

- (1) By not using a very expensive often troublesome connector module construction, but using our well known 8-channel In/output construction on one single front panel.
- (2) To choose the most advanced American way of console set up in which channel and group sections are consolidated into one Input/Output channel.
- (3) By not using the very expensive telephone goldplated patchbays, but to construct our own patchbay.
- (4) To use the latest techniques in integrated circuit design. It allows a reduction in the number of components (so: increasing reliability and reducing costs, an increased sophistication of circuit design and an overall performance which is unlikely to be significantly bettered for many years).

STANDARD FEATURES OF THE CONSOLE

- On each channel two parametric overlapping equalisers with constant Q.
- Overload indicators with memory device on every channel.
- Compact size and grouping of functions to allow a complete mix to be made without the need to move from the centreline of the console.
- Highly logical lay-out and clearly labelled functions.
- Delivered ready for instant installation with high-quality Amphenol multiway plugs and sockets. The plugs are supplied in advance.
- Performance specification equal to or better than those of any other design in this price.

CONFIGURATION

The console follows American practice in which channel and group sections are consolidated into one Input/Output channel. This configuration has several inherent advantages:

- Time spent transferring the console between the various modes can be almost eliminated.
- When changing from recording to overdubbing, cue systems remain available without any level modification. (1)



- Permanent fader and cue control allows an easy setting up to the last remix state without having to repatch and time consuming resetting of all the controls.
- There is much less waste of space and functions, many of which are essentially duplicated in the "European" configuration.

A great deal of thought and design detail has gone into the lay-out, designation of function and ergonomics of the console.

PHYSICAL DESCRIPTION

The console is extremely compact, built on bolted aluminium and wood, finished with mahogany. It is supplied complete with producers table and mounted on rigid steel legs.

All connections are made using multipin Amphenol connectors; the male connectors are supplied in advance for prewiring. Installation is then a matter of minutes.

The design has been consolidated into three basic modules, the Input/Output module, the master module and the patchbay.

48 Volts Phantom powering for capacitor microphones is standard.

The D & R consoles are built to the highest standards, using high quality components, glass fibre printed circuit boards, selected integrated circuits and first quality and reliable switches.

All components are mounted directly to the printed circuit boards which are mounted to the control components, so avoiding all the trouble associated with cheap plug-in systems.

All the input/output channels are wired directly to each other and to the master module. Separate power supplies for the integrated circuits, leds, Phantom powering and reed relays are taking care of click-free functioning.

All the power supplies are of a well-proven design, well smoothed and short circuit protected.



GENERAL FEATURES AND EASE OF USE

Mention has been made earlier of the ergonomic aspects of the console design. The guiding principle has been to examine each of the functions a recording engineer performs and to design the console to help as much as possible with each of them.

The console has basically three major states, these are normally:

- record
- replay/sync.
- remix

RECORD

All channels are set to accept mic or line level signals. The channel mode select is set to channel or group. Full equalisation is available, stereo headphones cue and 4 aux sends, all pre, mute or post switchable.

Routing to other channels or directly to the master is selected by the rotary routing controls.

The multitrack pot feeds the multitrack machine by way of the patchbay, and VU-meters are connected post patchbay to the multitrack inputs.

The solo switch gives the ability to listen to a selected channel in isolation without disturbing cue sends or other main channel inputs.

The mute switch performs both on the multitrack output and main channel signal path so no signal is coming out of the channel however the solo switch can still be activated.

The channel fader sets the level for monitoring purposes.

REPLAY / SYNC.

The only thing to do is to switch the channel mode selector to sync of the already recorded multitrack channel or to switch the input selector to remix to start already building up the remix state.

All cues are keeping the same level neither the panpot needs alteration nor the channel fader. The rotary routing controls are set to the master. The channel can also be set into the sync. mode by means of a reed relay, which is remote controlled in the master module, when many channels are to be recorded at the same time.



REMIX

All the input selectors are set to remix and channel mode selectors to channel.

When no subgrouping is necessary the rotary routing controls are selected to Master.

REMIX + RECORD

A mixing session very often involves overdubs as well either before the remix is started or because of a sudden change of mind by the producer in the middle of a session. In such a case the console has to be changed from remix to record state and back again.

Most of the already recorded channels are in the sync. mode on the channels. The situation is as follows:

- Connect the artists microphone to the mic input of the overdub channel.
- Set the channel mode selector on channel, and feed the multitrack machine by way of the multitrack level control.
- Activate the sync. remote switch of the sync. reed relays in the master module and the artist as well as the engineer can listen to the new incoming signal. (Almost all to-days multitrack recorders are giving the input signal at the output when not in replay or sync. mode).
- As soon as the multitrack machine starts it will give the sync. signal until the point of drop-in, at that point the machine gives - when it goes into record - its input signal at the output and the artist and engineer can monitor the new recorded signal.
- When the record button is released the tape signal comes out of the monitor and cue again until the next drop-in point.

Another way to do it is as follows:

- When the multitrack machine only gives the replay or sync. at its output terminals, and not the input signal.
- Connect the artist to a spare channel, give the artist his own cue signal and the engineer his monitor signal, and route the new signal to the overdub channel which has to be in the group mode.
- Multitrack level has to be set correctly by the multitrack level control.



- The remote sync. switch has to be activated, and the sync. signal comes on the cue and the monitoring in the overdub channel.
- As soon as the machine goes into the record state it will record the new signal until the record button is released and the sync. signal comes again on the cue and monitoring until the next drop-in point.

This way of making overdubs has the advantage that the artist can monitor himself while the multitrack machine is in the sync. mode.

When this set-up is used with a multitrack machine that always gives its input signal at the output when not in the replay/sync. mode, a rise of 3 dB in cue level is inevitable because the machine also gives the new to be recorded input signal in the cue system.

The only way to overcome this is to change the multitrack machine or to turn the level of the cue down on the spare channel at the moment of drop-in.

Attention:

All the other channels have been completely unaffected; there is no danger of changes, mistakes or the feeling that the remix has been altered in some way.

SUBGROUPING

On occasion it is desirable to subgroup inputs onto one or two busses to process the sound further as a group.

To do this the D & R console has the unique facility of patchfree audio subgrouping.

When the rotary routing controls are set to group the channel is freed from the master stereo busses, and can be routed to any of the 16 group amplifiers situated in the first 16 channels in stereo or mono.

The fader on each channel that has been routed to in this way becomes a subgroup fader when the channel mode selector is set in the group state and the rotary/routing controls to master. When it is desirable to subgroup this subgroup again it is only necessary to free the outputs again from the stereomaster busses and to process the signal further.

It is also possible to use the group amplifiers completely isolated from the channel on which it is located, the output of the group amps are connected to the patchbay as well. When this group output is patched



into the line amp of a spare channel or patched directly to the multitrack inputs, you can group any number of channels anywhere in the console.

This allows enormous flexibility of control!

The main features of the desk and its advantages should by now be clear.

On the next pages the individual modules are described in detail. Their lay-outs make them largely self explanatory as can be seen from the illustrations but there are a number of points that deserve expansion.

INPUT SECTION

A continuously variable mic gain control is provided to allow exact stereo fader line-up eliminating logarithmic errors. A continuous line gain control allows the matching of non standard input devices and rescuing of misrecorded multitracks.

The input to the channel is controlled by a stepped switch allowing connection to a microphone, line device or tape/sync. return.

The mic preamplifier will accept signals of 0 dBm with no pad in the circuit and deliver them at +22 dBm with less than 0,1 % TH distortion typical. A switchable 20 dB pad is provided for abnormally high inputs as well as a phase reverse switch.

The preamplifier noise figure, measured with a standard 200 ohm input load, is -127,5 dB (measured true RMS 20 Hz - 20,000 Hz).

The nominal output level is -6 dBm. The headroom of the preamplifier is 28 dB above -6 dBm; more than enough in this critical stage.



EQUALISER

The module incorporates a highly sophisticated 2 band parametric equaliser as well as the standard high and low frequency controls of proven design.

The high frequency control gives a continuously variable boost or cut of 18 dB at 15 KHz (other frequencies optional) with a shelving curve.

The mid high parametric equaliser has a range of 300 to 10,000 hz and the mid-low equaliser 80 hz to 1600 hz.

These two sweep equalisers are fully overlapping the mid band in the tone control stage.

Continuously variable frequency selection and boost or cut of 18 dB provides proper equalisation for almost any desired effect.

The low frequency control gives a continuously variable boost or cut of 18 dB at 50 hz with a shelving curve (other frequencies optional).

The equalisation can range from the most gentle to the almost equivalent of notch filters. It can even be used to provide flanging effects independently on every channel of the console.

An equaliser on/off switch is provided to bypass the equaliser circuit. The equaliser is of an unity gain design, delivering the best possible noise and headroom performance.

Headroom above nominal level is 28 dB and noise is below -100 dB typical.

CHANNEL STATUS

The channel mode selectors have three states:

- (1) Channel
In this state the whole channel acts as a normal channel.
- (2) Sync.
In this state everything situated below this switch is only in circuit to process the sync. signal output of the multitrack machine.
- (3) Group
In this state everything situated below is only in circuit to process the signal further which is coming from the output of the group amplifiers.



CUES

There are six Cue sends, allowing up to four separate foldback mixes or four echo sends at once.

Stereo cue is a permanent stereo headphones feed with panning.

All cues are switchable pre or post with a mute state in the middle.

ROUTING

When the two rotary routing switches are in the master position the signal, coming from the pan-pot goes directly to the master stereo busses.

When it is necessary to subgroup the signal it is only necessary to switch the routing controls to the desired subgroup.

The Pan-pot pans the signal between any odd numbered and any even numbered busses chosen by the routing switches.

Both routing switches have a mute state.

MULTITRACKS

The Multitrack level pot feeds the multitrack machine with a signal coming from the channel mode selector. It is wired to the patchbay and post-patchbay it is connected to the corresponding multitrack input on the multipole and VU meter.

When it is necessary to repatch the multitrack input to another channel or group output the corresponding VU meter goes with it.

For ease of use the multitrack VU meter only reads the input signal and not the output signal coming from the multitrack because this level doesn't need control again. Mostly it is correctly recorded and it only is confusing.



SOLO & MUTE

The solo switch gives the ability to listen to a selected channel in isolation without disturbing any signal processing.

The mute switch performs on both the multitrack output and channel fader, so no signal is further processed only the solo switch can still be activated.

OVERLOAD

The overload indicator is of an digital design. The unit incorporates a short term peakhold facility, so that even very fast peaks actuate it.

Because of these features one can be perfectly confident that there is no possibility of an overload at any point in the module.

CHANNEL FADER

The channel fader is a 100 mm carbon track audiolog instrument with a nice feel in hand when it is moved along its precisely indicated dB scale.

MASTER PANEL

Once again most functions are immediately apparent from the illustrations. The finer points are explained below.

Master Cue Aux group sends

These controls take care of overall level adjustment of the stereo headphones cue and the 4 aux sends.

The solo switch enables audio and visual control of the signal. The four aux master controls have their own VU metering.

The Program switch associated with the Cue master controls enables the engineer to interrupt the normal cue mix and to replace it with the stereo mix. This is useful when a separate cue mix is not needed. It is also very practical to give the musicians the complete controlroom monitor mix after recording or dubbing. So the timespent running from studio to control room is avoided with this feature.



Control Room Monitoring

Overall level control is a function of the master stereo fader and the Control Room level control.

The Monitors normally follow the stereo master output or the solo buss however by selecting one of the monitor source switches. 8 Stereo sources are available as shown on the illustration.

The alternative switch transfers the monitor feed to the internal loudspeaker for low quality monitoring.

Dim Switch

A Dim Switch is provided to momentarily lower control room monitor levels to facilitate conversation without losing previous monitor level settings.

A stereo/mono switch is provided to compare stereo and mono mixes.

Two trim controls are provided for optimizing level on the master output busses. For example, if a mix has developed satisfactorily but the overall level is too high, the trim pots can be used to attenuate all channels up to 15 dB. Similarly a boost of up to 15 dB can be given to an undermodulated mix.

Solo led

This led indicates when somewhere in the console a solo switch is activated. This is very useful when soloing on subgroups. The led indicates that it is a subgroup the engineer is listening to and not the master.

Oscillator

The oscillator is of a digital C. Mos design and gives a high stable sinus signal.

There is a continuously variable output control from 0 to +20 dBm. The frequency sweep control allows easy frequency checks from 50 hz to 15,000 hz within 1 dB.

The on/of rotary switch activates two states. When switched to Talk Back it is possible to have the TB-signal directly on the multitrack outputs as well as the stereomaster. When switched to Tone the oscillator signal goes directly on the Multitrack outputs and the stereo master.

In both states the dim switch is activated to avoid an irritating CRM level as well as howling round.



Talk Back

Two talkback amplifiers are built into the console; One with its own talkback mic, the other has transformer balanced inputs for communication practise.

The Talkback to Studio button allows the producer/engineer to insert the talkback signal into the stereo cue summing busses; it is interrupting the cue mix.

The Cue master level control is out of use when the talkback button is pressed, only the talkback level control is in circuit.

When the Talkback from Studio button is activated a talkback microphone placed in the studio comes on the solo buss making easy conversations possible between musicians and engineer/producer.

Power Supply

The power supply contains three separate transformers supplying plus and minus 18 Volts for the integrated circuits plus 48 Volts for the phantom powering and 24 Volts for the phase correlation meter and ancillary equipment.

A completely isolated power supply circuit with its own earth return is built in for the reed relays and the leds, so avoiding any clicks.

All three supplies are of a short circuit protected design, well smoothed and a capacity to supply current for a 32 in/output channel configuration.



SPECIFICATIONS

- The headroom of 28 dB is maintained throughout the entire console and represents a clip point at a genuine 22 dBm.
- Distortion will not reach the 0,01% typical.
- Frequency response is within 0,5 dB in the frequency range of 20 - 20,000 hz on all line level in- and outputs.
- The frequency range on the mic inputs is within ± 2 dB in the range of 40 - 20,000 hz.

OVERALL

- Output impedance 8 Ohm maximum.
- Maximum output level +22 dBm into 600 Ohm on all outputs.
- Breakpoint: output imp. 8 Ohm,
input imp. 10 kOhm, level -6 dBm.
- Max. gain through desk: 84 dB,
- Line level: -26 dB to +40 dB.
- 0 VU represents a genuine +4 dBm as standard practise.

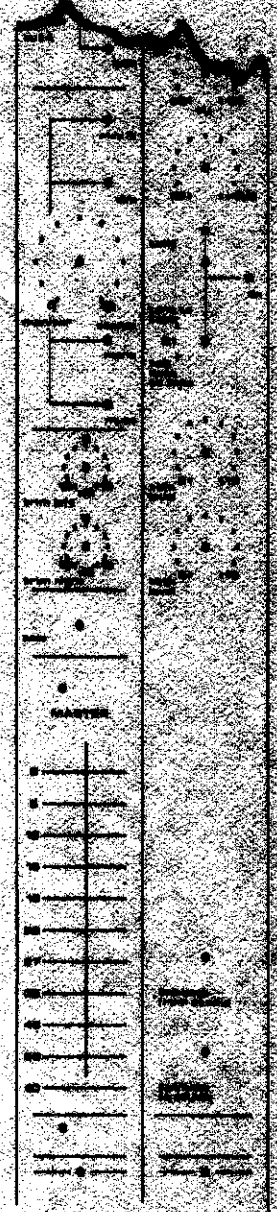
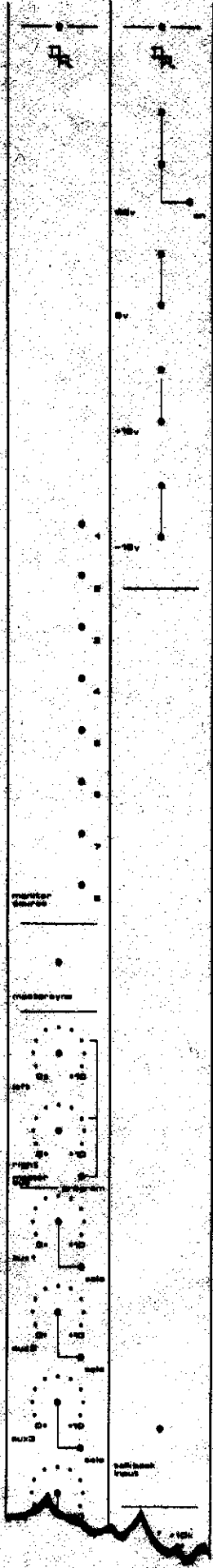
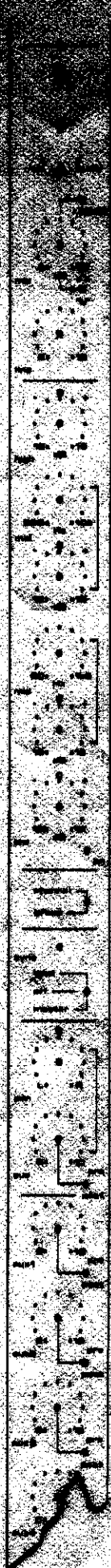



SI.1600 series

1	2	3	4	5	6	7	8	9	10	11	12	13	14	15	16
o	o	o	o	o	inputs	o	o	o	o	o	o	o	o	o	o
o	o	o	o	o	insertion out	o	o	o	o	o	o	o	o	o	o
o	o	o	o	o	extern equipment in	o	o	o	o	o	o	o	o	o	o
o	o	o	o	o	extern equipment out	o	o	o	o	o	o	o	o	o	o
o	o	o	o	o	insertion in	o	o	o	o	o	o	o	o	o	o
o	o	o	o	o	multitrack feed	o	o	o	o	o	o	o	o	o	o
o	o	o	o	o	multitrack input	o	o	o	o	o	o	o	o	o	o
o	o	o	o	o	multitrack return	o	o	o	o	o	o	o	o	o	o
o	o	o	o	o	group outputs	o	o	o	o	o	o	o	o	o	o

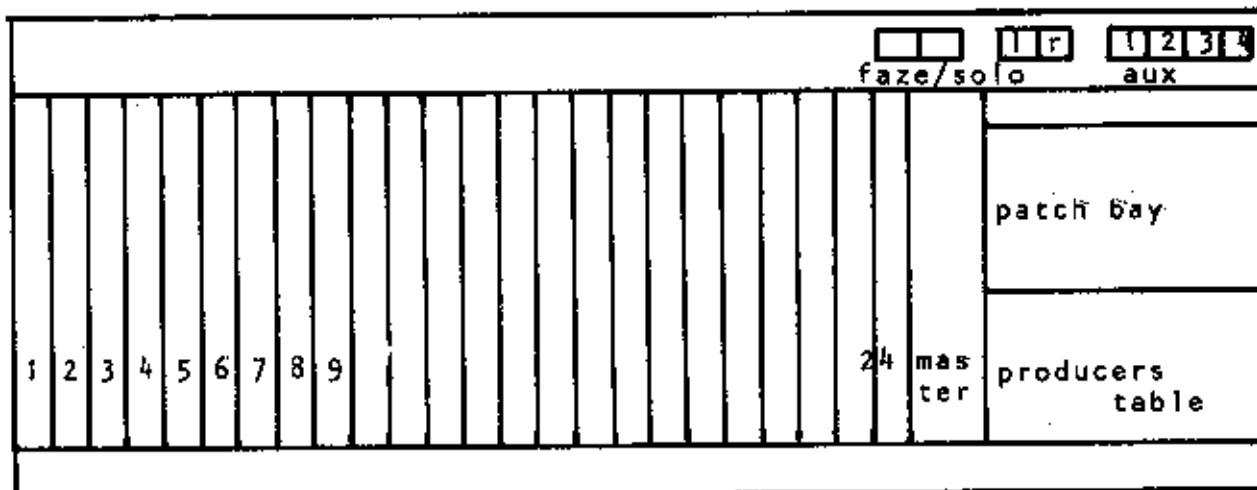
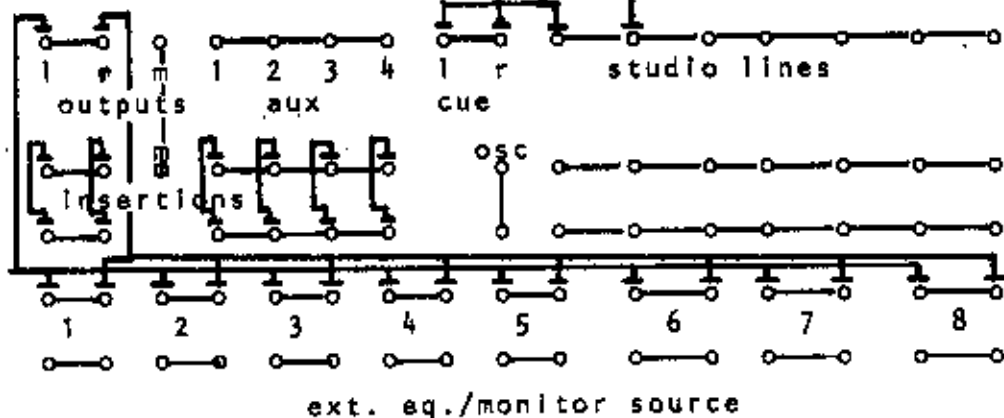
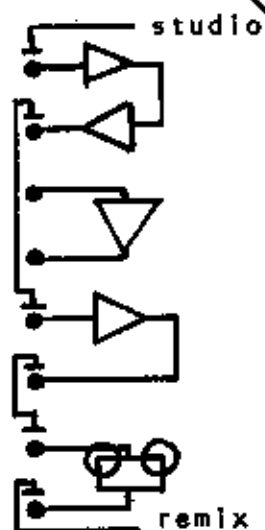



METERING

The following standard metering is built into the console:

- 16 Multitrack VU-meters.
- 2 Stereo master output VU-meters.
- 4 Aux send VU-meters.
- 1 VU-meter (PPM optional) coupled to the solo buss for channel level purposes.
- 1 Phase correlation meter.

MECHANICAL SPECIFICATIONS

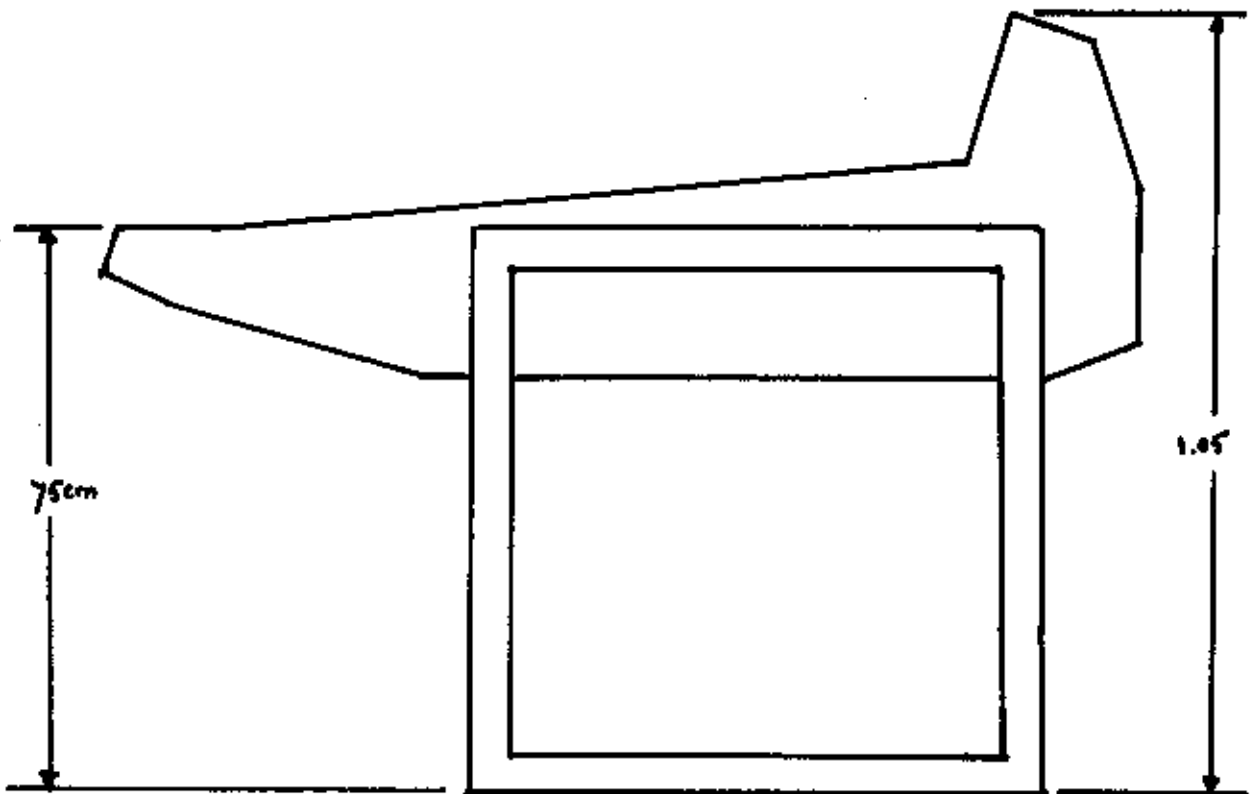



OPTIONS

To complete the concept of maximum flexibility, a number of options and accessories are available for the console.

- Any 8 channel configuration such as:
16, 24, 32, 40 channels.
- Other turn over frequencies on high and low frequency controls, even switchable as well as other sweep frequency ranges on the mid controls.
- High and low pass switches.
- Variable high and low pass filters are optional as an extension unit, such as Compressor/Limiters.
- Custom Faders.
- Upon request: PPM meters will be supplied instead of the normal VU-meters.
- Additional patch points on the patchbay.
- Additional monitor source switches on the Master module.
- Producers desk can be fitted with remote Talkback facilities, remote Dim, red/green light, as well as an ashtray.
- The upper part of the producers desk can be fitted with full remotes for the multitrack tape machine and for noise reduction units, echo remotes, varispeed, etc., etc.

--- Q ---

In accordance with our continuing policy of product improvement and development we reserve the right to modify or change designs without prior notice.



"ST 1600"

SERVICE MANUAL

DNR

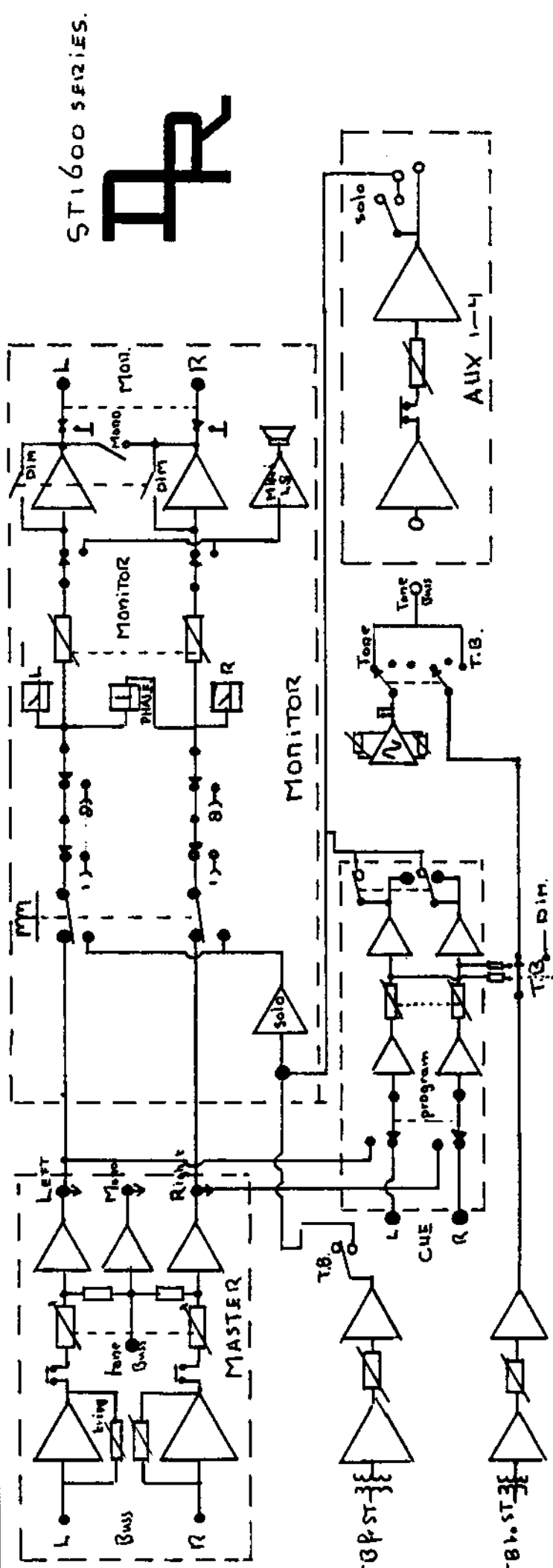
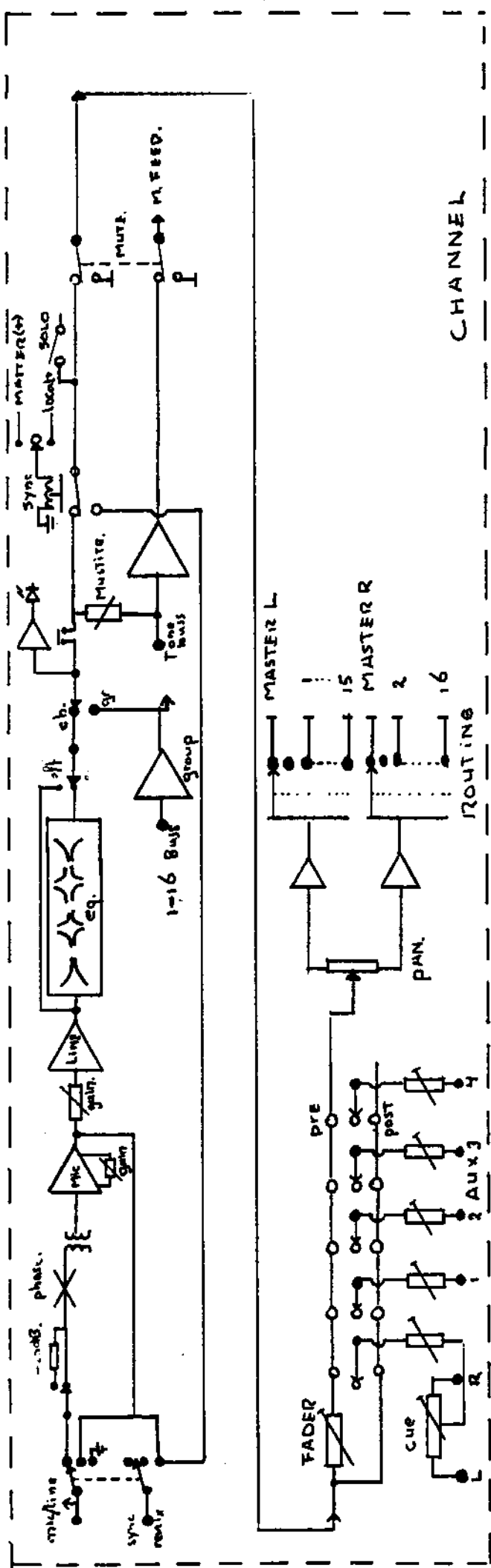

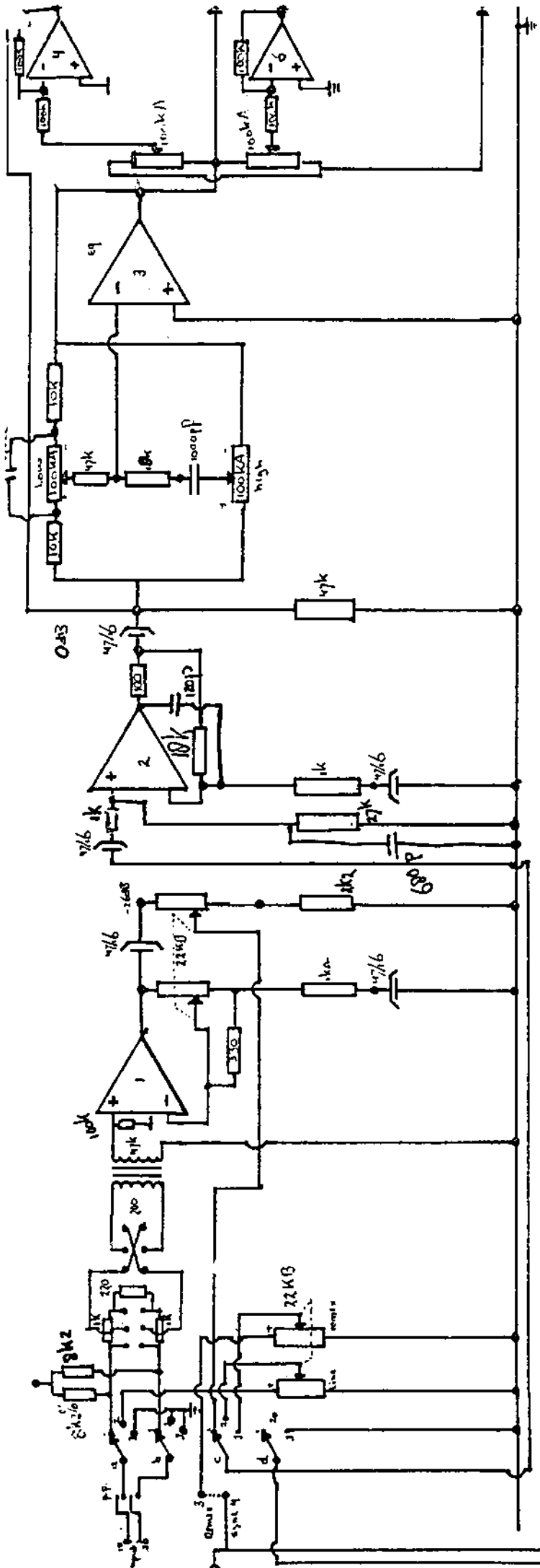

channel ST1600

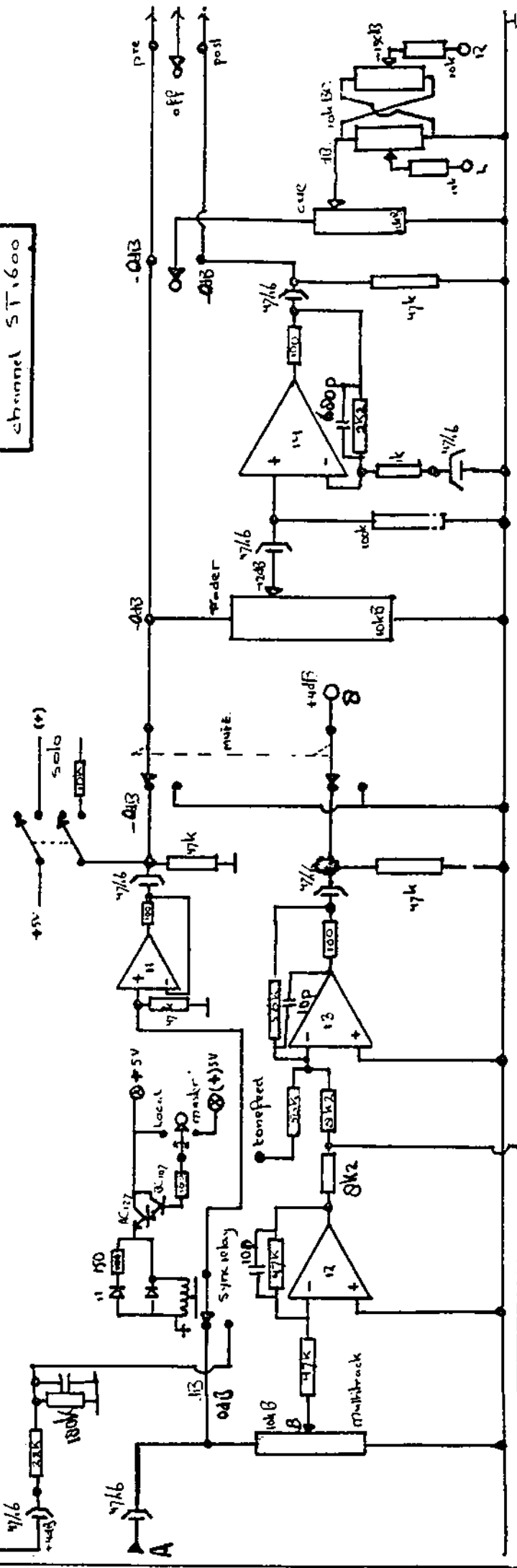

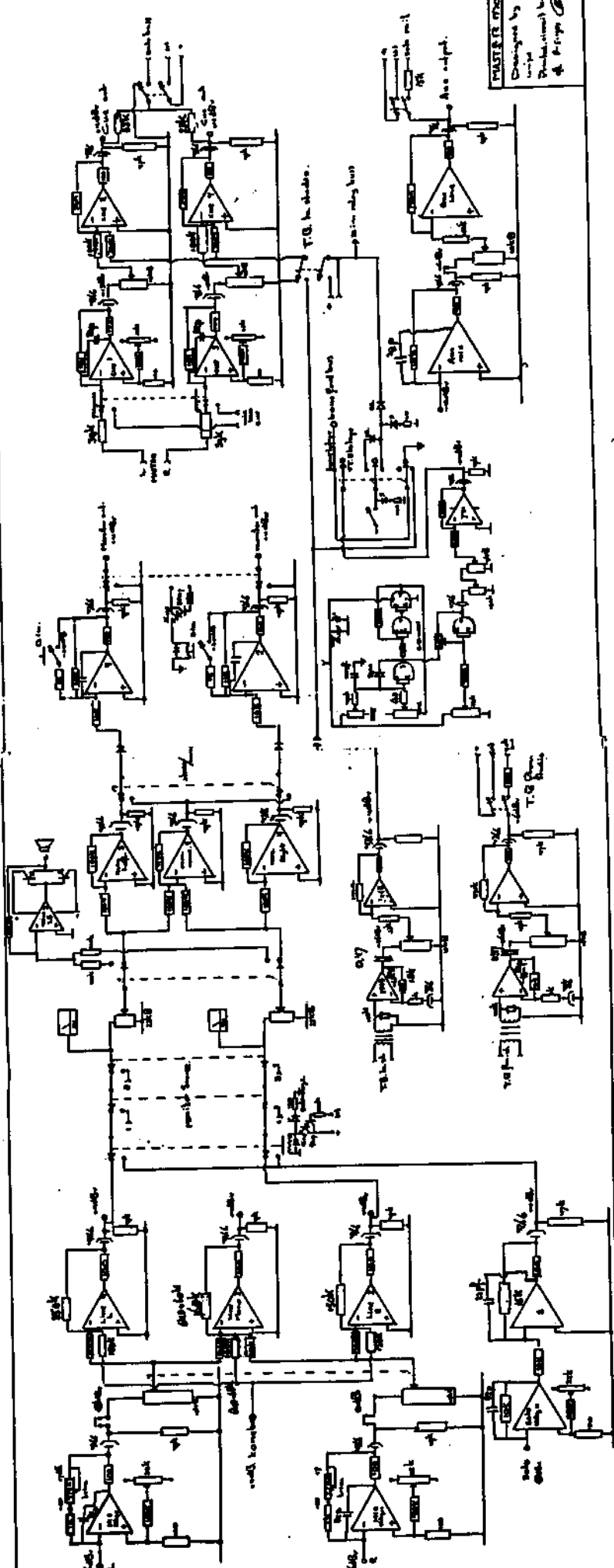

T.M.P. PRODUCTIONS
 Designed by D. M. P.
 Printed in the U.S.A.
 © 1978

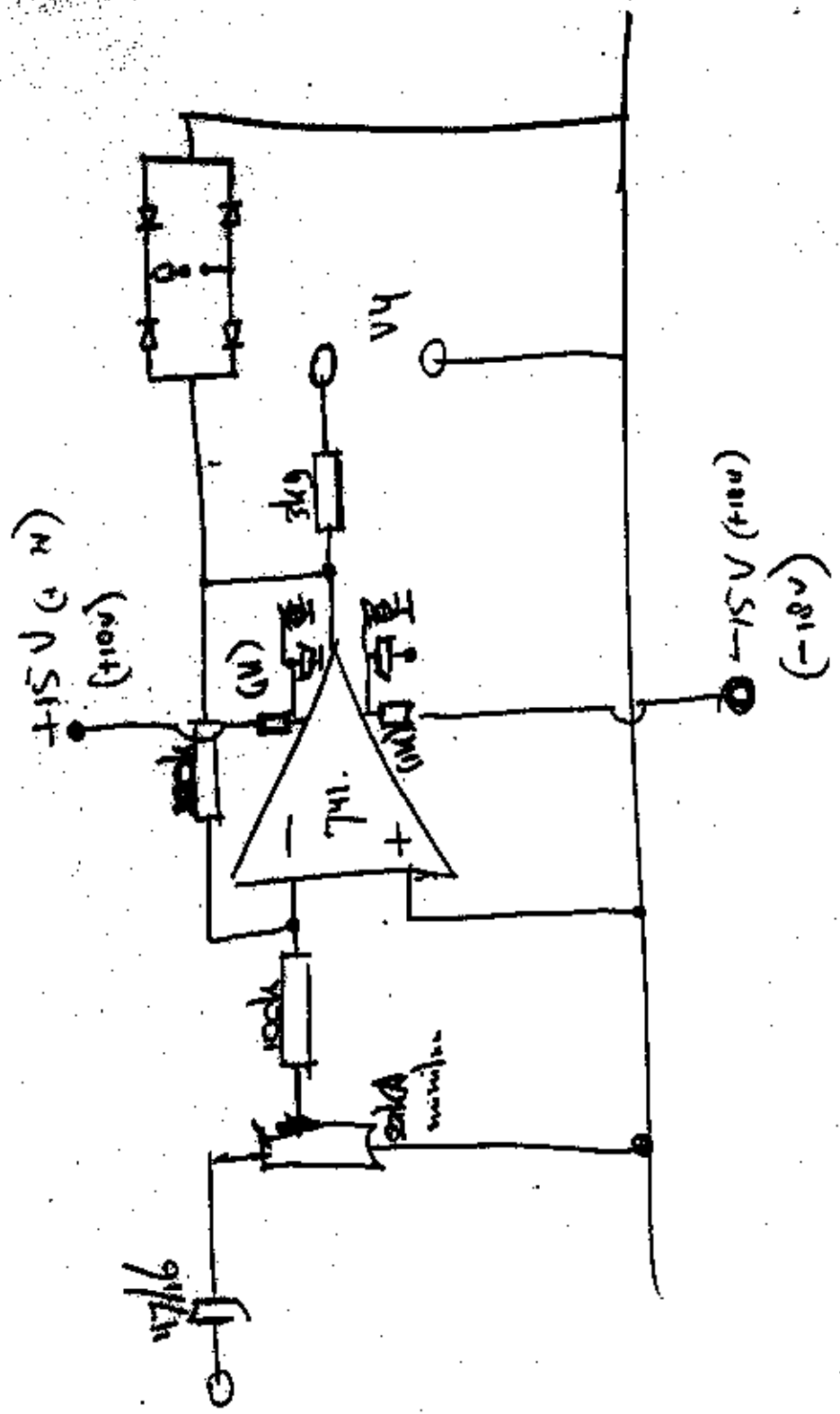

VU-meter
ST1600

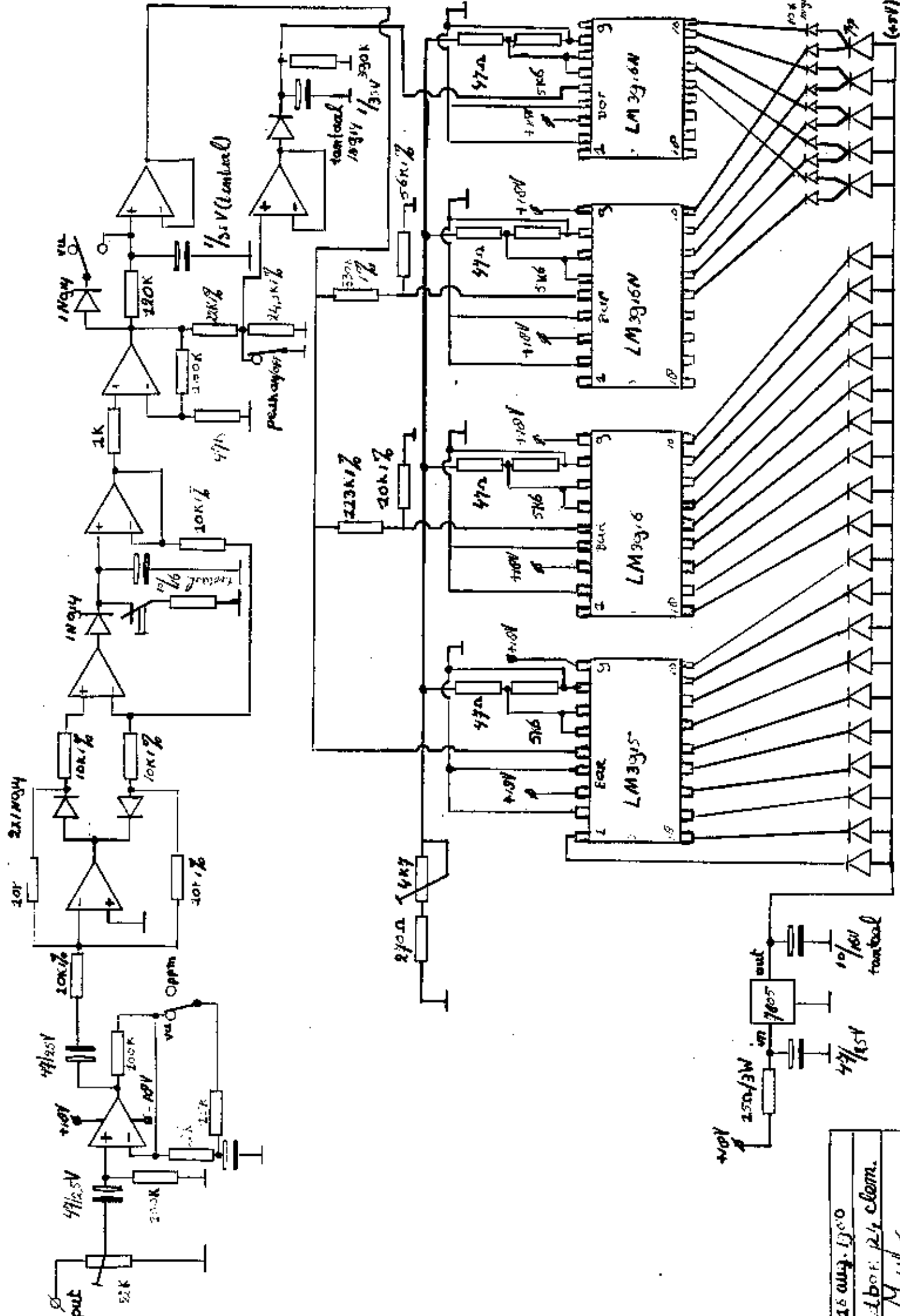

16 out of 100
 Lab. 24, clom.
 Moulk

Only the XR 8038 is disconnected from power - supply

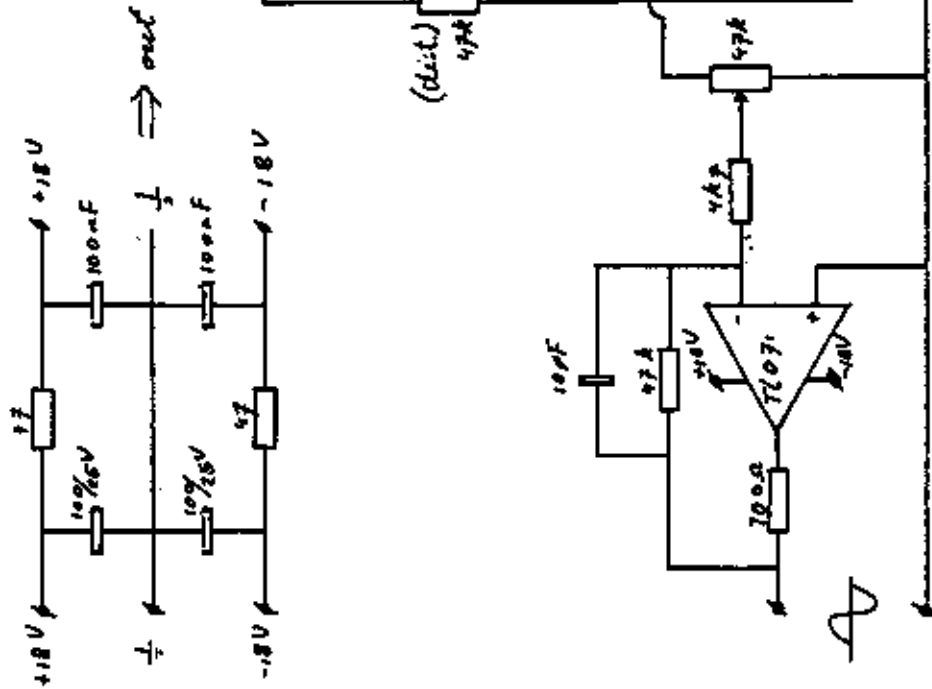

D & R
 sinus generator
 50Hz @ 15kHz
 UNIV STÄBEL SINNEN 0,3dB
 8-7-81

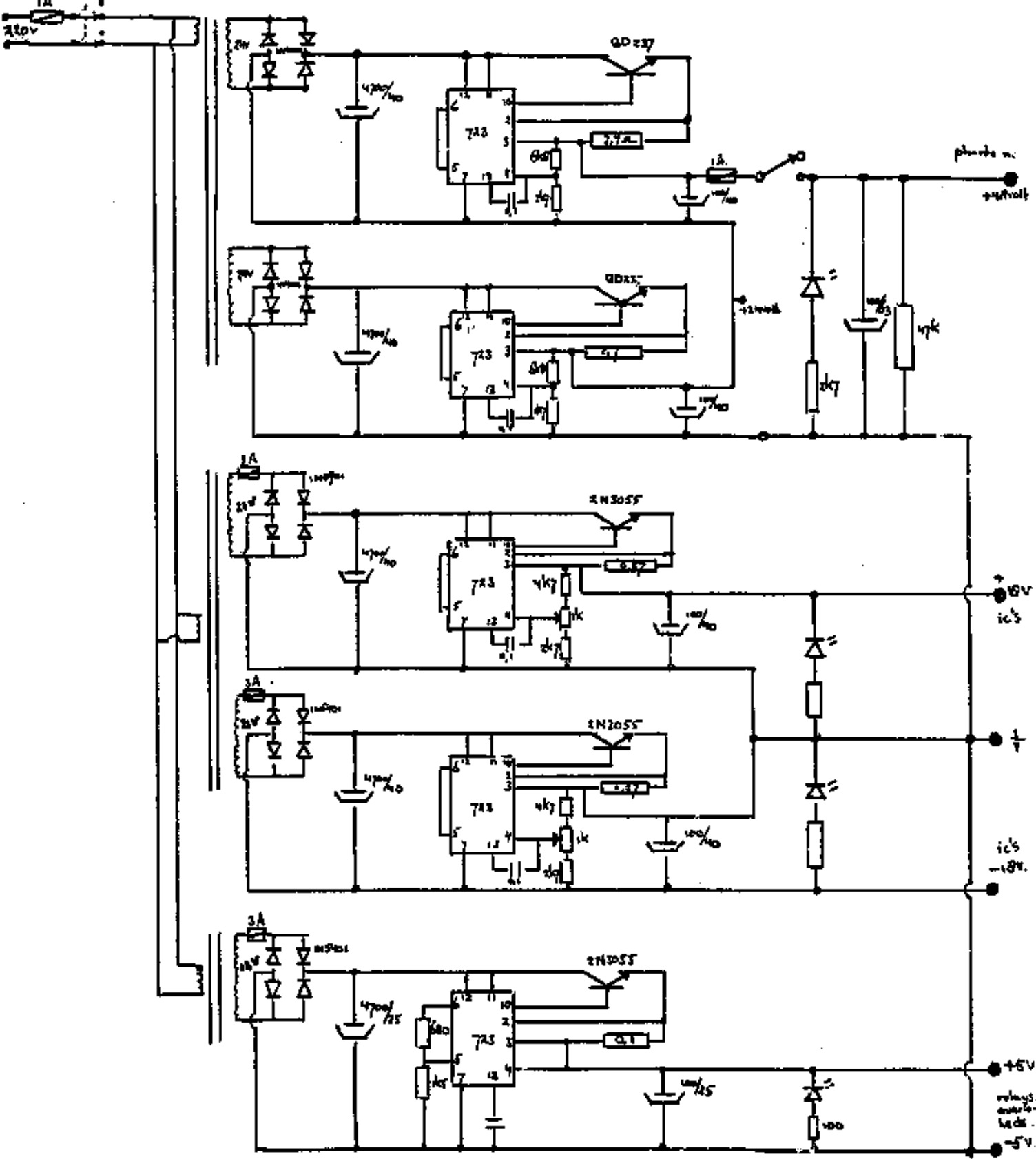

Power Supply ST1600
 Designed by D. Wright.
 Printed circuit boards W.N. Houshig.
 — 70 1978