

"MARILON"

USER MANUAL

DNR

Marilon Owners Manual

CONTENTS:

Introduction and Product Overview

1.0 The Chassis system - description

1.1 The chassis system

2.0 The Master section - description

- 2.1 Stereo effects returns 1 - 8**
- 2.2 Control room monitor module**
- 2.3 Studio/ solo module**
- 2.4 Stereo cue (phones) module**
- 2.5 Communications module**
- 2.6 Oscillator module**
- 2.7 Auxiliary master modules**
- 2.8 Master inputs/outputs**
- 2.9 Metering**

3.0 The "In-line" module - description

- 3.1 Ledbar section**
- 3.2 Assign section**
- 3.3 Input section**
- 3.4 Equalizer section**
- 3.5 Auxiliary send section**
- 3.6 Monitor section**
- 3.7 Channel/ solo/ mute section**
- 3.8 Fader section**
- 3.9 Inputs/outputs**

4.0 The Optional Patchbay - description

- 4.1 Optional patchbay - points**
- 4.2 Patchbay wiring**

5.0 Instructions for operation

6.0 Installation - electrical

7.0 Installation - audio

8.0 Troubleshooting and servicing

9.0 Connectors

10.0 Specifications

Dear client,

Thank you for selecting the D&R Marilon series.

The Marilon was created using the latest in computer aided design and assembling technology and incorporates the most advanced circuit components which results in the Marilon being another D&R product unsurpassed in the electronics industry.

We are confident that you will be using the Marilon for many years to come and wish you much success.

We always value suggestions from our clients and we would be grateful if you could complete and return the questionnaire included at the back of this manual once you become familiar with your Marilon. We learn from your comments and appreciate your time.

With kind regards,

D. de Rijk
President, D&R Electronica b.v.



Marilon Series

Recording Console

The D&R Marilon series is a totally balanced, 24-buss, in-line format recording and mixing console designed to take the central role in a recording facility.

The Marilon is completely modular, and can be configured to precisely suit your particular system requirements. Due to the fact that all inputs and outputs can be connected using the individual module and master section connectors, the Marilon patchbay is entirely optional. When the patchbay is installed, the Marilon offers you the opportunity to wire-up using multipins and individual input/output connectors. If you ordered your Marilon short loaded and without the patchbay, you may install the patchbay at a later date.

To become completely familiar with your Marilon and gain the maximum benefit from its use, we recommend that you read this manual thoroughly. It will provide important information about all aspects of the Marilon including; installation, operation, and servicing.

Head Office / Factory

D&R Electronica B.V.
Rijnkade 15B
1382 GS Weesp
The Netherlands

Tel: (-) 31 2940 18014
Fax: (-) 31 2940 16987

U.S.A. Office

D&R U.S.A.
Rt. 3, Box 184-A
Montgomery, TX 77356
U.S.A.

Tel: (409) 588 3411
Fax: (409) 588 3299



THE CHASSIS SYSTEM

1.0 The Chassis System

The Marilon is available in two frame sizes; 57 position and 73 position. The basic frame has five blank modules, two are located on the extreme left and right of the frame, two more are on the left and right of the master section, and the fifth is located to the left of the patchbay. These locations cannot be used for in-line modules, as they conceal mechanical constructions, wiring, and power distribution.

The 57 position frame will fit 32 in-line modules, patchbay, 8 master modules, and 5 blank modules. The standard configuration has (from left to right) 24 in-line modules, 8 master modules, 8 in-line modules, and patchbay. Custom configurations are available at no extra charge. The 57 position frame can accept up to 44 in-line modules if the patchbay is not utilized.

The 73 frame can accept up to 48 in-line modules, master section, and patchbay. Larger frames are optional. The standard configuration has (from left to right) 32 in-line modules, 8 master modules, 16 in-line modules, and patchbay. Custom configurations are available at no extra charge. The 73 position frame can accept up to 60 in-line modules if the patchbay is not utilized.

Both the master section and patchbay can be installed wherever most suitable, but the request must be made at the time of ordering. Unless otherwise specified, the 57 position (frame-82) will be supplied with twenty-four input channels left of the master section, eight input channels on its right, and the patchbay located in the far right position. If your requirements are for your patchbay to be remotely mounted, ask D&R for a custom quote.

Unless otherwise specified, the Marilon 48 frame has: (left to right) 32 inputs modules, master section, 16 input modules, and patchbay.

The Marilon legs are not assembled for shipping. Assembly takes approximately twenty minutes.

THE MASTER SECTION

2.1 Stereo Effects Returns

There are eight stereo effects returns located on the top portion of each master section module. On each of the stereo returns is a mono switch which can be used for any effect that only has one output. A gain control (below the mono switch) is for matching the output level of different devices to the effects return inputs. A two band stereo equalizer is fitted to EQ the effect return signals. Aux sends 5 & 6 can be sent separately while aux 7 & 8 are sent via one stereo control. This control is used to send effects returns to the stereo cue (phones) system. A balance control, solo & mute switch, and 60mm fader complete each stereo return.

2.2 CRM Module

The CRM (control room module) module contains the electronics for monitoring all the signal paths in the Marilon.

CRM Source switching

From top to bottom there are the five CRM signal sources. With all these switches in the up position, the CRM will monitor the stereo main outputs which is the sum of all the monitor sections and L/R routing switches in the input/output modules as well as all 8 effects modules.

The Marilon has four dedicated balanced +4 dBv or -10 dBu tape return inputs which can be wired to the outputs of stereo master machines, cassette, CD player or DAT recorders. Utilising any of these switches enables playback or post tape monitoring of a master mix.

Aux 7-8 can be monitored in stereo to allow the building-up of a stereo cue mix for the headphone system through the control room monitors.

CRM level

The CRM level controls the total outgoing level to the CRM 1 - 2 - 3 monitors. When in the full clockwise position, a balanced signal of +4 dBv is given out to the CRM monitor amps. It is important to have the monitor amps correctly adjusted. You should adjust the CRM monitor amps (input level controls) to an undistorted level with the CRM level control fully clockwise.

NOTE: This alignment is imperative in order to avoid damage to the tweeters, or in some cases damage to the ears of the listener.

Three Monitor Systems

The Marilon has three CRM systems intended for use with large monitors, small monitors, and nearfield monitors. We advise that nearfield monitors be wired to the CRM 2 output, as the studio communication takes place over this monitor while dimming the main monitor. CRM 3 is designed for connection to small monitors or other alternative monitoring purposes. Switches are used for selecting the desired CRM system.

DIM

A Dim switch drops the level of the CRM by 20 dB while leaving the level control at the desired position.

MONO

The Mono switch allows the user to check for any out-of-phase signals or simply used for monitoring your mix in mono.

The Master Section/CRM Module.....continued

MUTE

Also fitted in this section is a mute switch to allow you to completely mute the CRM.

Faders

Located in the bottom of the CRM & Studio modules are two mono faders which control the main stereo mix busses.

2.3 The Studio/ Solo Module

STUDIO

The Studio section performs in a similar way to the CRM module, sending signals to the studio amp from the CRM or Aux 7-8. This section has a mute switch and level control with level ranges up to a balanced +4 dB nominal level (+26 dB maximum). The mute switch is used to mute the output of the studio module.

SOLO

The Solo section has a level control and master status switching for the PFL (mono) or Stereo solo-in-place system. A solo active LED is fitted to show when the solo system is active.

2.4 Stereo Phones Module

PHONES

This module has a stereo level control, mute switch, and source switching from the CRM section or Aux 7 & 8 sends which are used for a stereo headphone mix.

2.5 Communications Module

Communications

The communications module performs all communication functions between the control room, studio, and any other rooms linked into the circuit.

T.B.

When you depress the T.B. (talkback) switch, a built-in electret microphone sends the control room conversation to several destinations, such as tape, studio, phones, and to a backpanel connector.

LISTEN

When you depress the (locking) LISTEN switch, a two-way communication can be performed between the studio and control room. An extra input on the back panel of this module is fitted for a mic which can be mounted in the studio. The LISTEN control will allow you to set the level of that mic through the CRM 2 speakers.

REMOTE

The REMOTE switch will allow the user to activate the optional wireless remote talkback switch or the optional footswitch.

The Master Section.....continued

2.6 Oscillator Module

At the top of the module is the three frequency oscillator which is a low distortion phase shift model. The three frequencies are 100Hz, 1kHz, and 10kHz. Each frequency has its own front panel alignment trimmer and overall level (LVL) control with which to precisely align the oscillator for precise alignment of the console and tape machines. The level ranges from -35 dB to +20 dB with a marked mid-position of +4 dBv.

The oscillator can either be routed to the AUX send busses, GROUPS, or an output socket on the module backpanel which is activated by the EXTERN switch.

NOTE: the CRM dim is activated when the oscillator is active.

2.7 Auxilliary Master Modules

The auxilliary master modules are identical in function. One module controls the Aux sends 1 - 4 and the second module controls Aux sends 5 - 8.

The Aux 1 - 8 masters control the Aux 1 - 8 signals from the channels. The mute switch completely mutes the balanced output, however, the afl switch continues its signal to the control room monitors which is a postfader signal. The associated led lights, indicating the activated solo switch.

The meters on the Marilon are peak reading meters and therefore read -6 dB when a sine wave with a +4 dB output level sent to the meter. Measuring the +4 dB output level of the channel or master with a AC voltmeter would give a 1.22 volt reading. The led meter would actually be reading -6 dB on the scale. When monitoring "program" material, you will see higher levels on the peak reading meters.

The Master Section backplate connections

2.8 Master In/Outputs

The Marilon has two methods of interfacing with external equipment such as signal processors, headphone amps, and power amps. Interfacing is possible using the connectors on the master bottom panels, through 25 pole sub D male connectors, or a mixture of both. Listed below are all inputs and outputs for the eight master modules.

Master module # 1 (effects return # 1) The inputs/outputs backpanel provides inputs for effects return # 1 left and right as well as two track A · B · C · D left inputs. All inputs on this module are balanced 1/4" connectors; tip = hot, ring = cold, & sleeve = ground.

Master module # 2 (effects return # 2 and CRM) The inputs/outputs backpanel provides inputs for effects return # 2 left and right, two track A · B · C · D right inputs, and CRM 1, 2, & 3 left and right outputs. All inputs and outputs on this module are balanced 1/4" connectors; tip = hot, ring = cold, & sleeve = ground.

Master module # 3 (effects return # 3 and Studio) The inputs/outputs backpanel provides inputs for effects return # 3 left and right, master left insert send and receive, +4dB master left output (XLR), -10 dB master left output, as well as studio left and right outputs. All inputs and outputs on this module are balanced 1/4" connectors; tip = hot, ring = cold, & sleeve = ground unless indicated.

Master module # 4 (effects return # 4 and Phones) The inputs/outputs backpanel provides inputs for effects return # 4 left and right, master right insert send and receive, +4dB master right output (XLR), -10 dB master right output, as well as phones left and right outputs. All inputs and outputs on this module are balanced 1/4" connectors; tip = hot, ring = cold, and sleeve = ground unless indicated.

Master module # 5 (effects return # 5 and Communications) The inputs/outputs backpanel provides inputs for effects return # 5 left and right, remote talkback switch output, studio "listen" mic input, power supply connector, and three ground posts.

Master module # 6 (effects return # 6 and Oscillator) The inputs/outputs backpanel provides inputs for effects return # 6 left and right and the oscillator output. All inputs and outputs on this module are balanced 1/4" connectors; tip = hot, ring = cold, & sleeve = ground.

Master module # 7 (effects return #7 and Aux 1, 3, 5, & 7) The inputs/outputs backpanel provides inputs for effects return # 7 left and right, and outputs for aux sends 1, 3, 5, and 7. All inputs and outputs on this module are balanced 1/4" connectors; tip = hot, ring = cold, & sleeve = ground.

Master module # 8 (effects return # 8 and Aux 2, 4, 6, & 8) The inputs/outputs backpanel provides inputs for effects return # 8 left and right, and outputs for aux sends 2, 4, 6, and 8. All inputs and outputs on this module are balanced 1/4" connectors; tip = hot, ring = cold, & sleeve = ground.

Master Metering

2.9 Metering

The Marilon is fitted with peak reading, high resolution, ledbar meters with attack and release times which conform to world standards. The attack is 10msec. for a 20 dB range, and the release is 1.5msec.

NOTE: Peak reading meters give a reading 6 dB below the actual level when using a sine wave. For example, +4 dBu at the output connectors would give a reading of -6 dB on the meter using the oscillator.

If U.K. reading ledbars are ordered, they will have attack and release times of 800msec. and a +4 dBu level on the connectors will give a 0 dB reading on the scale.

If analog meters are mounted, when reading "0" on the VU meter you should have a +4 dBu or 1.22 volts on a volt/ohm meter.

Another standard feature of the Marilon, is a "phase correlation" meter. This meter measures the phase relationship of two signals between 0 and 180 degrees. Due to the advanced circuitry of the Marilon, all signals between -40 dB and +20 dBu will give an exact reading of their phase relationship. If only one signal is presented to the phase meter, the circuitry will prevent the meter from registering a reading.

All readings up to 90 degrees are acceptable for mono compatability. Readings above 90 degrees might cause problematic mono compatability and should be avoided. This can be done by accurate microphone placement and/or reversing phase on the channels.

The In-line Module

3.0 The In-Line Module

The Marilon in-line module is a basic input/output design whereby all signal flow takes place from the microphone to the multitrack. The following sections explain its many functions and features.

3.1 Led Bar Graph Meters

The 13 segment led bar graph meter is a peak reading device with attack and release times in conformance with world standards. It reads the level travelling to or from the multitrack, depending upon the monitor section's "tape" switch setting.

NOTE: The first led in the bargraph is a power supply indicator.

3.2 Assign section

The routing gives selection to the 24 multitrack output busses using seven pushbuttons. The "red" colored pushbutton indicates assignment to its own multitrack summing amp.

The bounce switch (bnc) alternates between 1 - 12 or 13 - 24.

With every pair of summing amps you have the choice of assigning to the odd or even amp, using the channel panpot in the channel strip, (dark colored section).

The Marilon's summing amp and internal structure means that it is extremely quiet and distortion free, therefore a direct button to bypass the amps is not necessary. Every channel is individually assigned to the multitrack input which allows for mixing to be simple and consistent.

3.3 Input Section

The input section controls all incoming signals from microphone, line, and tape.

A +48V phantom power switch for condenser microphones or direct boxes can be silently switched in or out of the circuit.

The pad inserts a 10 dB attenuation into the mike input amp. If the signal source is too loud, this switch can be used in conjunction with the mike/line gain to give increased control on the channel faders.

Line A switches the mike input to line A input on the channel. The line has its own balanced input amp and is controlled by the active (dual) gain control.

Phase is used to reverse the phase of any mike/line input coming from a mike or signal that may be out of phase with other mikes or signals. A successful method of checking for "out of phase" signals is to depress the mono switch on the master section and listen closely to the mix. If an unexpected sound is heard, or if something appears to be missing from the mix, depress the phase switches for those channels suspected to be in error. If the sound improves, then that channel was out of phase with the others.

The In-line Module.....continued

If using multiple mikes on the same signal, such as drums, vocals, horns, strings etc., it is possible to create an acoustical phase cancellation. In most cases, physically moving the mike's a few inches will correct this phase cancellation. In addition, the Marilon's phase meter can be helpful with this problem.

The dual concentric gain controls are the single most important controls on the console. With these controls accurately set, it is possible to achieve the very best signal to noise ratio and maximum headroom required for high quality recordings. The top control is for adjusting the line/mic input and the bottom control is for adjusting the tape return input.

After plugging in a mike or line signal, depress the channel solo switch above the channel fader you are setting, set the solo status switch to pfl in the master section, then turn the gain control clockwise until a "0" output level is reached on the master meters. Now slide up the channel fader to "0". If the signal source gets louder or softer, it may be necessary to re-check this setting. The volume will also fluctuate if you boost or cut the equaliser section.

The TAPE gain is an actively controlled feedback type gain control with a range of 40 dB. Any incoming tape or line level signals can be actively controlled using this control. The tape input normally feeds the monitor section but can alternatively be switched to the channel path using the "MIX" switch.

NOTE: It is important to ensure that the signal being miked remains at a constant volume when recording begins or the above setting procedure will need to be carried out again. You should do this procedure for every mike input or line input in order to achieve the high quality performance D&R products are renowned for.

Mix, (the record-mix status switch) selects the basic signal path in the module. When in the record mode ("up" position) the mike/line input signal is routed through the channel path with or without equalisation and/or aux sends and then to the long fader and channel panpot. It can then be sent to the main L/R bus and/or be assigned to the multitrack busses.

With the mix switch in the "up" position, the multitrack inputs or outputs are heard through the monitor section.

When in the mix mode ("down" position) the channel signal flow is rerouted; mike/line inputs are assigned to the monitor section (light colored), and the tape input is rerouted to the channel path. This can be regarded as an input flip switch, mike/line and tape input are reversed.

3.4 Equaliser Section

This four-band parametric equaliser can be switched (in pairs) into the channel or monitor paths.

The **Highpass** filter is a fixed 12 dB per octave Butterworth model which reduces low frequency noise effectively and musically. It can be switched on or off in the channel path.

The **HF** (high frequency) section is a constant Q type resulting in precise shaping of sounds without adding additional side-band noise. The high frequency section ranges from 1000 Hz to 20,000 Hz with a maximum boost or cut of 16 dB. This band has a 1.5 fixed "Q" factor.

The **LF** (low frequency) section is a constant Q type resulting in precise shaping of sounds without adding additional side-band noise. The low frequency section ranges from 50 Hz to 1,000 Hz with a maximum boost or cut of 16 dB. This band has a 1.5 fixed "Q" factor.

The **BELL** switch allows you to change the HF and LF bands from bell (peak/dip) to shelving. The high frequency and low frequency sections can be inserted in the channel or monitor path.

The In-line Module.....continued

The HMF (High/Mid Freq.) section has level and frequency controls and is also a constant Q type, therefore the bandwidth setting will match that of the level control. The frequency ranges from 1,000 Hz to 20,000 Hz and has a maximum boost or cut of 16 dB. The bandwidth has a Q factor of 1.5.

The LMF (Low/Mid Freq.) section has level and frequency controls and is also a constant Q type, therefore the bandwidth setting will match that of the level control. The frequency ranges from 50 Hz to 1,000 Hz and has a maximum boost or cut of 16 dB. The bandwidth has a Q factor of 1.5.

The HMF and LMF bands can be switched in or out of the channel and/or monitor circuit paths. If the equaliser is only partly inserted in a signal path, the equaliser on/off switch has priority over the monitor switches. All level controls are center detented making neutral positions easy to establish.

All frequency ranges have been carefully selected following extensive examination of all types of music (and noise) which makes this equaliser a pleasure to work with. Noise and distortion are kept to an absolute minimum.

3.5 Auxilliary Send Section

The Marilon has eight auxilliary send busses, switchable to twenty four. Auxilliary sends 1&2 are on concentric controls, the top one for Aux. 1 and the lower one for Aux. 2. Aux 3&4 are on concentric controls also. All four can be fed from either the channel path or monitor and are pre/post switchable.

Auxilliary 5-8 are similar to auxilliaris 1-4 having channel/monitor and pre/post switching. Aux 5&6 can be routed to the multitrack busses to net a total of 32 aux send busses.

Auxilliary 7-8 are a stereo pair. The top knob is the level control. The bottom control knob is the pan, capable of moving the signals from left (Aux. buss 7) to right (Aux. buss 8) in the stereo image of a foldback or cue (headphone) mix.

During recording, Auxilliaris 7-8 are the preferred sends to use as headphone sends. A stereo image can be easily constructed by adjusting the level and pan control knobs.

During mixdown, Auxilliaris 7-8 can be made available as an extra input and assigned to the stereo mix buss by pressing the line B switch. This input is accessable on the backplate of the in-line module or in the optional patchbay.

3.6 Monitor Section

The monitor is the second signal path in the Marilon in-line channel.

In record mode (the mix switch in the up position), the monitor section is fed by either the tape return or group output (tape return or tape send).

In mix mode (mix switch depressed), the monitor section is fed by the mic/line input and the tape return now moves to the channel and is controlled by the long fader.

The In-line Module.....continued

Two bands of the equaliser (as earlier stated) can be inserted into the monitor section making the monitor path a fully functioning input usable in the mix mode for other signals different from the signal present in the channel. Both channel and monitor paths can have mic/line or tape inputs chosen with a full bandwidth equalizer (on each) at the same time.

Auxiliary sends can be assigned to both channel or monitor in groups of four. Both signal paths have their own PFL (pre fade listen), stereo solo in-place, and mutes.

The tape switch allows you to choose from where the monitor gets its signal. In the up position (source), the channel fader feeds the monitor through summing amps 1-24. For channel selections above 24 the channel fader will feed the monitor directly. In the down position (tape), the tape return (monitor in) feeds the monitor signal path.

NOTE: The channel's ledbar display follows this switch.

The GRP (group) switch inserts the monitor fader into the multitrack summing amps of that particular channel. All relevant functions of the monitor section are also inserted. The stereo solo-in-place or pfl system and mute can be used on this group fader as well as auxiliary sends and equaliser, but the monitor signal path is obviously lost. The mix channel status switch has no influence on the group switch.

The monitor and channel fader can be reversed (REV) when use of the large fader for monitoring during recording is preferable. All functions such as assigned Aux. sends, solo, and mute functions stay in their actual signal path. Only the faders are electronically reversed.

The SOLO switch has two modes; pfl (pre fade listen) or a "destructive" stereo solo-in-place system. Master status switching (located in the master section) selects the "solo in-place" or "PFL" mode for the entire console.

Activating the solo switch in the pfl mode will send the prefader signal of the monitor section to the CRM speakers. In the solo in-place mode, the post monitor panpot signal is heard, and all other channels are muted within the stereo mix buss. A solo indicator LED is fitted next to the solo switch.

The MUTE system is a special soft-muting integrated circuit, completely click-free. A mute indicator LED is fitted next to the mute switch.

NOTE: Always make sure that unused monitor sections are muted as the unterminated inputs will degrade the excellent low noise performance of the mixing amps.

3.7 Channel Solo / Mute Section

A PEAK LED is fitted to allow for proper input level adjustment of the mic or line input.

The L/R switch assigns the channel panpot to the stereo mix buss while the channel PAN control pans the signal between the main stereo mix L/R busses and/or the odd and even multitrack summing busses if assigned.

The mute and solo systems are identical to the monitor system, refer to section 3.6 in the monitor section portion of this manual.

3.8 Fader Section

The Marilon has a separate fader section with a high quality 100mm fader. Alps or P&G faders or various moving fader automation systems are available. The Marilon's mute system can be integrated in the C-Mix fader automation system. Moving fader systems can also be built into the unit, please ask for details and a quotation.

3.9 In-line Module Input and Output connectors.

In addition to the optional patchbay, every channel also has the following connectors at the bottom of the housing.

Balanced XLR connector for the microphone input.

- Pin 1 = ground
- Pin 2 = hot (in phase)
- Pin 3 = cold (out of phase)

The balanced line "A" input is a stereo 1/4" jack socket:

- Tip = hot
- Ring = cold
- Sleeve = ground

The balanced line "B" input is a stereo 1/4" jack socket:

- Tip = hot
- Ring = cold
- Sleeve = ground

The balanced channel inserts are on two stereo jack sockets:

- Tip = hot
- Ring = cold
- Sleeve = ground

The channel inserts are on two balanced stereo jack sockets. The send socket has the inphase signal on the tip, and the ring is ground compensated to earth. The sleeve is ground, level 0 dB. The send socket is normalled to the return socket and balanced with the tip as the inphase input, and the ring as the out of phase input. The sleeve is ground.

The monitor section input is a 1/4" stereo jack socket which has a level adjustment on the front panel adjustable +/- 20 dB. The tape machine outputs must be wired to these monitor inputs in order to monitor the multitrack tape channels.

The balanced monitor input is on a stereo jack socket:

- Tip = hot
- Ring = cold
- Sleeve = ground

The balanced monitor inserts are on 1/4" stereo jack sockets:

- Tip = hot
- Ring = cold
- Sleeve = ground

The monitor inserts are on two balanced stereo jack sockets. The send socket has the inphase signal on the tip, and the ring is ground compensated to earth. The sleeve is ground, level 0 dB. The send socket is normalled to the return socket and balanced with the tip as the inphase input, and the ring as the out of phase input. The sleeve is ground.

The two group outputs are on balanced stereo jack sockets:

- Tip = hot
- Ring = cold
- Sleeve = ground

The default setting on these outputs are +4 dBu. A setting of -10 dBV can be chosen on the channel board using jumper settings.

The group output will be connected to the multitrack input from this socket or via the multipins on the patchbay, whichever best suits your requirements. The extra output jack socket is used for aux sends when you do not have the optional patchbay (the first output would be wired to the multitrack tape machine).

THE OPTIONAL PATCHBAY

4.0 The Optional Patchbay - description

The recessed patchbay section is built around Bantam type tiny telephone jack sockets. This optional patchbay is completely modular and designed to allow the user or installation person to hook-up the cables between the channel modules and patchbay modules. It can be expanded as your budget allows or ordered complete. All master inputs/outputs and 144 tie lines (for signal processing) are standard when you order the patchbay.

The whole patchbay is balanced and internally "starground" wired. Each four rows of channel patch points are followed by four channels of multitrack inputs and outputs. The multitrack patch points are also optional. The patchbay can accept a maximum of 48 channel sections and up to 32 channels of multitrack inputs and outputs.

All interfacing is via 25 pin sub "D" connectors which accept eight balanced pairs of signals per connector.

4.1 Optional Patchbay - points

Channel patch points from left to right are:

Line "A" input - Line "B" input - channel insert send & return - monitor input - monitor insert send & return - group output.

The tape inputs and outputs (if ordered) are normalled to group outputs and monitor inputs.

The master section contains six rows of Bantam type jacks.

First Row: Left master insert send & return, right master insert send & return, +4 outputs left & right, -10 outputs left & right.

Second Row: Tape or mastering machines A, B, C, & D inputs left & right.

Third Row: Tape or mastering machines A, B, C, & D outputs left & right.

Fourth Row: Tape, DAT, CD, and two track machine playback inputs to CRM.

Fifth Row: Aux send outputs 1 thru 8.

Sixth Row: Two sets of four mults (parrallels).

Tie Lines: The tie lines (144 in total) are in rows of eight. The tie lines are for any signal processing equipment. For ease of use, all outputs are on blue sockets, and all inputs are on black sockets.

4.2 Patchbay Wiring

All interfacing with external machines, effects, or amplifiers, can be done via the connector panels on the bottom plates of the console or via the multipins on the patchbay connector panel.

If the optional patchbay is installed, the connector system is 25 pole D-type. The cabling must be wired to male 25 pole sub-D type connectors. All the connectors are able to handle eight balanced signals and are wired identically. The wiring is also silk screened on the patchbay connector panel. The installation section of this manual gives wiring schemes for all connectors in the Marilon.

5.0 Instructions for operation

The Marilon is designed to be the perfect answer for multitrack and MIDI studios. In order to get more familiar with the Marilon, we shall discuss the entire recording process and divide it into five basic sequences. Sequence 1 through 4 are for the more conventional recording studios, and sequence 5 is for the MIDI studio.

- 1. The session** - Recording from microphone or line input onto the multitrack machine. This could be from one or more channels at a time.
- 2. The playback** - In this mode you would listen to what has been recorded on the multitrack machine.
- 3. The overdub** - Overdubbing is listening to already recorded tracks and recording on empty tracks until all tracks are filled.
- 4. The remix** - Playing of all recorded tracks together with signal processing equipment and all that is necessary to create the final mixdown.
- 5. The MIDI or Virtual Tracking** - Programmed keyboards, drum machines, reverbs, effects, Aunt Susie singing and who knows what else, all at the same time direct to your Dat Machine, two track master machine, or cassette deck.

Sequence 1 - The Session

Record - This is the beginning of a session. All input channels are placed in the mike mode by leaving the line switch in the up position if the microphone input is to be used in this channel. Phantom powering is applied if necessary. The EQ switch should be in the up position unless you require EQ on that mike. The signal flows through the fader and is available postfader to be routed by way of the assignment switches on top of the module which can feed the input to your multitrack recorder. The LED bargraph reads the outgoing signal.

Microphone/Line Gain

The amount of gain required may depend on the type of microphone being used, the sound pressure level, and the distance between the sound source and microphone. A 10 dB pad can be inserted where levels are too hot. When the line switch is activated, the same gain control varies the gain of the separate electronics for the balanced line input. The "phase" switch affects both the mike and line inputs.

Monitoring

With the Marilon series, you are able to monitor your multitrack by way of the separate monitor section. The monitor section of the in-line module allows you to have two usable inputs, both with EQ, both being able to send to the aux. busses, both with their own volume control, panpots, mutes and solos, and all routed at the same time.

Multiple Modules Assigned to One or Two Tracks

When more than one microphone or line signal has to be recorded on a single track or in stereo on two tracks, a submix facility is required. This can be done easily on the Marilon by way of the the internal subgroup amplifiers located on every channel module. Simply route to one of the 24 subgroups by activating a channel routing switch on as many input modules as required. Decide on which track you wish to record these signals and activate the related number. The channel metering will show the subgroup level which can be changed overall by the monitor group fader (Grp switch has to be depressed). In order to monitor these tracks on the modules, the tape switch in the monitor section should be in the up position for monitoring pre-tape (console out) and in the down position for monitoring post-tape (tape switch down).

Operation instructions.....continued

Insert Channel/Group

For high dynamic range types of inputs, a signal processor such as a compressor/limiter can be inserted in the channel or even in the monitor insert if an entire group signal needs to be processed. To do this, it is necessary to activate the GRP switch in the summing channel to use the monitor insert.

Headphone (Que)

During recording it is essential that the talent hear an independent mix of what the engineer and producer are hearing. Headphone mixes are usually derived from pre-fader auxiliaries. In the Marilon aux 7 - 8 are ideal for this purpose. The best way to build a mix for the headphones is to have the monitor section of the in-line module feed aux busses 7 and 8. When there is limited time to set up a headphone mix, give the talent the CRM mix and build up a new headphone mix on aux 7 & 8.

Effect Sends

All unused aux sends can be used to send signals to signal processors such as the D&R "Qverb" 16 bit digital reverb, effects processors, and digital delays. The aux sends are usually post-fader in order that the right balance between untreated and treated signals is maintained however, it is possible to switch to pre-fader.

Effects Returns

In the modern recording or MIDI studios of today, there is a demand for many effect returns. For that reason D&R has designed the Marilon with 8 stereo effects returns as part of the master modules. Any unused channel or monitor input can also be used for returning effects. Every channel can accept two returns with equalization and aux send capabilities.

Sequence 2 - The Playback

Multitrack playback

The Marilon gives you a convenient way of monitoring your multitrack recorder. Put all the tape switches in their down position. Now the tape outputs are feeding the monitor path and you can adjust the amount of signal you desire and pan it within the stereo image.

Auxiliary sends and equalisation can be inserted in both signal paths whenever needed. Control over this processing is carried out by independent solo/mute systems in both signal paths.

Sequence 3 - The Overdub

Multitrack synchronizing

Overdubbing is the process of building up a recording track by track while listening to previously recorded tracks.

The Marilon has an in-line monitor for each track of the recorder making it easy to overdub. In the monitor section of the in-line module, you push all tape switches down and do all your sync switching from the tape machine or remote. The headphone mix is done on the aux send 7 and 8 busses. Aux 7 and 8 should get their signal from the monitor section. It is best to activate aux 7 - 8 pre-fader switches.

Operational instructions.....continued

Sequence 4 - The Remix

Multitrack mixing

Remix is the process of combining all recorded tracks with (keyboards and drum machines for MIDI) signal processing and sending the mix to a two track master machine, DAT machine, or cassette recorder. On the in-line module you must push the "mix" switch down. This routes the tape return to the channel input and routes the mike/line inputs to the monitor section of the module.

At this point, you can use either a mike or line input into the monitor and it will feed the stereo mix buss if required. This will give you two inputs per module in the mix down. You can activate the EQ to "mon" switches and have the high and low, and/or HMF and LMF sections of the equalizer on the monitor.

You must activate the EQ switch if you desire EQ on the channel or monitor. The incoming signals can be routed to the stereo mix buss via the L/R switch in the channel section. The monitor section normally feeds the stereo mix buss. Sub groups can be made up (as required) in the same way as during recording. You can have aux sends 1 - 8 getting their signal from the monitor section or channel path in sections of four.

If you need more aux sends, remove the outputs of aux 5 & 6 from their respective busses by depressing the switch labeled BUSS 1-24. You can now use the multi-track assign switches as extra aux send busses which will get their signal from aux 5 & 6 sends on each channel. This extends the number of aux send busses to 30.

Sequence 5 - The MIDI or Virtual Tracking

Virtual Tracks: The MIDI Set-Up

In most MIDI studios there will be an eight-track rather than a sixteen or twenty four track tape machine. The majority of music production is programmed on a sequencer using MIDI keyboards, sound modules, drum machines, or other MIDI related equipment.

Therefore, you will only require tape tracks for vocals and those instruments not adequately reproduced on today's keyboards. If there is a multitrack recorder in the MIDI studio, one of the tracks would be used to record a time code (SMPTE or MIDI code). This will allow your sequencer to keep keyboards, drum machines, and other MIDI equipment synchronized.

The Marilon was designed with the multi-track and MIDI studio in mind. In today's medium to large MIDI studio, there is a need for as many as 100 inputs to be used for everything from tape tracks to keyboards and drum machines. In the 32 frame Marilon (32 in-line modules & patchbay), you can have 112 inputs in the mix session. The 48 frame Marilon would net 160 inputs in the mix session or virtual tracking session.

Each in-line module is designed to net three inputs per module, each with level control, panpot, and mute switch. Two of the three inputs per module can have a full bandwidth equalizer at the same time and feeds to the aux sends. The three inputs are; the channel, monitor, and line "B" which is aux 7 & 8 when the line "B" switch is pressed.

NOTE: When aux 7 & 8 are used for the extra line input, it would not have access to the EQ or other aux sends.

6.0 Installation - Electrical

Local Electrical Voltage

Before connecting the Marilon, check the AC supply voltage setting by looking at the sticker on the back of the rack mount power supply. This should be 110V for use in areas with an AC supply between 100V and 120V, and 220V for use in areas with an AC supply between 220V and 240V.

The main fuse should be 6.3 amp, 20mm (fast blow) for 110V service, and 8.15 amp, 20mm (fast blow) for 220V service. The phantom power supply fuse should be a 2 amp fast blow and the +/- 18V supply fuses should be 6.3 amp, 20mm fast blow. If one or more of the power supply LED indicators should go out, turn off the power supply and check the fuses on the front panel of the rack-mount power supply. After replacing a blown fuse with the correct size and rating, turn the power supplies on and check the three LED indicators. If you are still missing one or more of the power rails, turn off the power supply and call the D&R Technical Support Department. **DO NOT REPLACE THE FUSE WITH ANY OTHER TYPE AS THIS CAN BECOME A SAFETY HAZARD AND WILL VOID THE WARRANTY.**

Electrical Wiring

To take full advantage of the excellent signal to noise ratio of the Marilon, it is necessary to read this part of the manual carefully.

Hum, radio frequency interference, buzzes and instability are often caused by improper wiring and poor grounding. Sometimes the incoming electrical ground is inadequate and a dedicated ground would need to be installed for the audio equipment.

Your local electric power company will provide you with all local electrical codes and safety regulations. There are some grounding rules to follow. All signals in a recording studio are referenced to ground. This ground must be clean and free of noise. A central point should be selected as the main grounding point and all grounds should originate from this point. This is commonly referred to as a "star ground system".

In some instances electrical contractors will daisy chain ground connections. This is unsuitable for a studio. Ideally, run a separate ground wire from each outlet and a separate ground wire for each piece of equipment. A separate wire from each equipment rack to the dedicated ground point is useful in cases where AC outlet grounds are not satisfactory. The dedicated ground point should be located at the rear of the console or equipment rack. Separate and identify "clean" and "dirty" AC outlets. Use clean outlets for audio equipment and the dirty ones for lighting, air conditioning, freezers etc. Do not intermix these two types of outlets. AC interference can be greatly reduced by using an isolation transformer (Juice Goose) to power clean outlets. Ground this transformer directly to the dedicated ground point or as close as possible to the incoming ground.

All equipment should be physically located as far as possible from the main breaker panel. Unbalanced equipment may require isolation from the equipment rack so that ground loops are avoided.

7.0 Installation - audio

7.1 Interface CRM Levels

The Marilon in its standard configuration can interface with all available equipment.

Attention concerning CRM output must be noted. This output delivers a balanced nominal +4 dBu level which is sometimes too high for power amps rated at 300mV sensitivity for full output. In some instances an input attenuator at the power amp's input is required to reduce this +4 dBu level by up to 12 dB. Contact the D&R Technical Support Department for details.

7.2 The Initial Hook-Up

First connect the rack-mounted power supplies (two supplies are provided with the 32 or 48 chassis) to the console. All faders, monitors, and effect returns must be in the "down" or "off" position. In order to ensure the best signal to noise ratio for your system, the next steps should be performed in the order they are printed.

a. Connect the CRM outputs (located on the master module backplate) to the inputs of your control room speaker power amps. Now turn on the console power supply and then turn the power amp on and check for any hum, buzz, or interference. Slowly turn the CRM control clockwise until it is wide open while listening for excessive noise. You should only hear a faint "hiss". If everything is O.K., continue. If any hum or excess noise is present, stop and try different ground and shielding arrangements until the system is clean.

b. Before making any other connections move each monitor fader to the 0 dB position with the tape switch depressed on each monitor section. Connect the multitrack outputs to the tape return XLR's on the backplate of each in-line module (or via the 25 pole sub-D connector if the optional patchbay is installed), then connect each connector on the tape output of your multitrack. Check for hum or noise after each track has been hooked up. "Hiss" will normally increase slightly with each track. Connect the tape send output jacks to the inputs of the multitrack. Carefully listen for excessive noise or hum. If after hooking up an input or output excessive noise or hum is detected, stop and take corrective action before proceeding. **Do not hook up all 16, 24, 32, or 48 tracks and then listen.** You may need to rewire the entire cable harness to make the system clean.

c. Connect stereo tape recorders (inputs and outputs), stereo headphone amp, and all signal processors.

NOTE: MAKE SURE THAT YOU CHECK FOR HUM OR NOISE AS EACH INPUT OR OUTPUT IS CONNECTED.

7.3 Shielding and Grounding of Audio Equipment

The shield of any audio cable connection should be connected at one end only. If not, ground loops and high frequency cross-talk could result. Connect the shield as a general rule to the signal source (output) of anything. In high RF areas it is wise to ground the other end of the shield through a 0.01 microFarad capacitor. This will ground the RF but will not affect audio frequencies.

Installation - audio.....continued

7.4 Typical Interface Situation Table

Output	Input	Connect shield at:
Unbalanced	Unbalanced	Output
Unbalanced	Balanced	Output
Unbalanced	Differential	Output
Balanced	Unbalanced	Input
Balanced	Balanced	Output
Balanced	Differential	Input
Differential	Unbalanced	Output
Differential	Balanced	Output
Differential	Differential	Output

Use the above table to interface your Marilon to any external equipment such as multi-track machines, signal processing, and power amps. Balanced (in the above illustration) means transformer balanced while differential means electronically balanced. There are some cases which net better results in practice. Connect one circuit at a time and check for hum or noise. When connecting balanced microphones, use two conductor shielded audio cable and connect both conductors and the shield at both ends.

When connecting line level cables, use two conductor shielded cable and follow the instructions in the interface table. The only exception to these rules is with patch cords. These grounds are tied together in the console. We realise that the correct interfacing of all different equipment is difficult, but once properly installed the system will be clean and noise free.

It is important to understand the term balanced. Balanced does not mean the input or output is professional, the single factor that normally determines whether something is professional is the level of the input or the output. +4 dBu is considered professional. -10 dBv is considered semi-professional. Because many semi-professional tape machines are built to professional specifications, D&R builds into its console series the ability to interface with both levels.

7.5.1 Master section modules.....Aux return # 1

Aux 1 Return Left Tip = hot
 Ring = cold
 Sleeve = ground

Aux 1 Return Right Tip = hot
 Ring = cold
 Sleeve = ground

2 Track A Left Return Tip = hot
 Ring = cold
 Sleeve = ground

2 Track B Left Return Tip = hot
 Ring = cold
 Sleeve = ground

2 Track C Left Return Tip = hot
 Ring = cold
 Sleeve = ground

2 Track D Left Return Tip = hot
 Ring = cold
 Sleeve = ground

Installation - audio.....continued

7.5.2 Master section modules.....Aux return # 2 & CRM

Aux 2 Return Left	Tip = hot Ring = cold Sleeve = ground
Aux 2 Return Right	Tip = hot Ring = cold Sleeve = ground
2 Track A Right Return	Tip = hot Ring = cold Sleeve = ground
2 Track B Right Return	Tip = hot Ring = cold Sleeve = ground
2 Track C Right Return	Tip = hot Ring = cold Sleeve = ground
2 Track D Right Return	Tip = hot Ring = cold Sleeve = ground
CRM 1 Left	Tip = hot Ring = cold Sleeve = ground
CRM 1 Right	Tip = hot Ring = cold Sleeve = ground
CRM 2 Left	Tip = hot Ring = cold Sleeve = ground
CRM 2 Right	Tip = hot Ring = cold Sleeve = ground
CRM 3 Left	Tip = hot Ring = cold Sleeve = ground
CRM 3 Right	Tip = hot Ring = cold Sleeve = ground

Installation - audio.....continued

Module # 4continued

Master Output Right -10 Tip = hot
 Ring = cold
 Sleeve = ground

Phones Output Left Tip = hot
 Ring = cold
 Sleeve = ground

Phones Output Right Tip = hot
 Ring = cold
 Sleeve = ground

7.5.5 Master section modules.....Aux return # 5 & Communications

Aux 5 Return Left Tip = hot
 Ring = cold
 Sleeve = ground

Aux 5 Return Right Tip = hot
 Ring = cold
 Sleeve = ground

Remote Talkback Switch In Tip = hot
 Ring = cold
 Sleeve = ground

Studio Listen Mic Input Tip = hot
 Ring = cold
 Sleeve = ground

Power Supply Cable Pin 1 =
 Pin 2 =
 Pin 3 =
 Pin 4 =
 Pin 5 =

Ground Terminals Main
 Shield
 Patch

7.5.6 Master section modules.....Aux return # 6 & Oscillator

Aux 6 Return Left Tip = hot
 Ring = cold
 Sleeve = ground

Aux 6 Return Right Tip = hot
 Ring = cold
 Sleeve = ground

Oscillator Output Tip = hot
 Ring = cold
 Sleeve = ground

Installation - audio.....continued

7.5.7 Master section modules.....Aux return # 7 & Aux sends; 1, 3, 5, & 7

Aux 7 Return Left Tip = hot
 Ring = cold
 Sleeve = ground

Aux 7 Return Right Tip = hot
 Ring = cold
 Sleeve = ground

Aux 1 Output Tip = hot
 Ring = cold
 Sleeve = ground

Aux 3 Output Tip = hot
 Ring = cold
 Sleeve = ground

Aux 5 Output Tip = hot
 Ring = cold
 Sleeve = ground

Aux 7 Output Tip = hot
 Ring = cold
 Sleeve

7.5.8 Master section modules.....Aux return # 8

Aux 8 Return Left Tip = hot
 Ring = cold
 Sleeve = ground

Aux 8 Return Right Tip = hot
 Ring = cold
 Sleeve = ground

Aux 2 Output Tip = hot
 Ring = cold
 Sleeve = ground

Aux 4 Output Tip = hot
 Ring = cold
 Sleeve = ground

Aux 6 Output Tip = hot
 Ring = cold
 Sleeve = ground

Aux 8 Output Tip = hot
 Ring = cold
 Sleeve = ground

This concludes the master section module connections. Refer to section 7.0 of this manual for usefull ideas and wiring techniques.

Installation - audio.....continued

7.6 Connecting the In-Line Module

Description:	Connector:	Connect:
Mic input (balanced)	Female XLR	Pin 1 = shield Pin 2 = hot + Pin 3 = com -
Line input A & B (balanced)	1/4" Stereo plug	Tip = hot Ring = com Sleeve = ground
Channel insert send & return	1/4" Stereo plug	Tip = hot Ring = com Sleeve = ground
Monitor in (tape return) balanced	1/4" Stereo plug	Tip = hot Ring = com Sleeve = ground
Monitor insert send & return	1/4" Stereo plug	Tip = hot Ring = com Sleeve = ground
Group out (2 tape sends) balanced	1/4" Stereo plug	Tip = hot Ring = com Sleeve = ground

Use -10 dBv jumper settings on the PCB's for Fostex type equipment and +4 dBu connections for Studer and Sony type's.

The **MIC INPUT** is used for plugging in all types of microphones or direct boxes. This is an active balanced input using the latest circuit technology available today. Each channel module has 48 volt phantom powering individually switchable. **DO NOT USE EXTERNAL PHANTOM POWER AND THE POWERING IN THE CONSOLE AT THE SAME TIME!**

The **LINE INPUTS** are used for plugging in the outputs of digital reverbs, digital delays, drum machines, samplers, keyboards, CD players, cassette machines and any machines with line level outputs.

CHANNEL INSERT and **MONITOR INSERT** sends and returns are used to patch (pre-fade) into the channel or monitor any signal processing equipment such as compressors, limiters, equalisers etc.

MONITOR INPUT is used for connecting the output of your multitrack tape machine or the outputs of any effects (such as digital delays, digital reverbs, aural exciters, etc). This track or effect will now appear in the monitor section if the tape switch is depressed. If the mix switch is depressed, this track or effect will appear in the channel and be controlled by the channel fader. If the mix switch is depressed, this track or effect will appear in the channel and be controlled by the channel fader. The microphone input or line input will now appear in the monitor section of the same module. It will be controlled by the monitor fader, and panned onto the stereo mix buss. This allows you to mix two completely independant signals on the same module.

The **GROUP OUTPUTS** (tape outs) are used as a summed output of any channel. It will appear as a direct output of the channel when you push the color-coded assign switch and the BNC switch in the routing section. The extra output is used for Aux 7&8 when line "B" is used.

Troubleshooting and servicing

8.0 Troubleshooting

It is essential to study the signal flow chart carefully, only then can you hope to isolate problems. By tracing the signal from input to output jacks, it is possible to locate a problem. If for any reason you are unable to isolate a problem, contact the D&R Technical Support Department for advice. If the problem cannot be corrected over the phone, D&R will despatch a replacement module (freight prepaid) the same day. Most problems can be found using logical thinking and simply replacing socketed integrated circuits.

8.1 Removing a Module

The Marilon is a complex piece of equipment and some understanding of its internal layout is necessary before removing a module.

An input module has wiring to the ledbar, fader, master section and backplates, and to the star ground system. All of these wires must be removed before withdrawing a module from the console. Each module has computer grade connectors for ease of the disconnect.

Turn off the power supply. Remove the backplates behind the ledbar and underneath the monitor fader section first. Then remove the two backplate screws which hold the input/output connector. Now remove all flat cables from the bottom of the module PCB. It is often easier to also remove the backplates positioned left and right of the module under test. Remove the ledbar wiring and the two star ground cables connected to the module. Finally, remove the metal cover underneath the ledbar front, which conceals the screws retaining the module. It is now possible to remove the two module retaining screws and carefully lift the module until the fader wiring can be unplugged. At this point extender cables (if ordered) can be connected.

The master sections can be removed from the frame in the same way.

Because of the many flat cables on the bottom of the master section, it is wise to remove all retaining screws from all master sections, and remove the blind panel on the right side of the master section. This will allow all the master modules to be moved slightly without unplugging all the flat cables. A qualified service technician will be able to service the modules in this way.

NOTE: The left blank panel protects the power distribution board, and need not be removed.

Patchbay

The patchbay is fully modular and can be serviced after first removing the backplates, then removing the cables attached to the card that needs servicing. The card can be removed after unscrewing two screws that push the patchpanel card downwards. The card will still be connected to the star ground system, which will need unplugging before the card comes free of the console wiring.

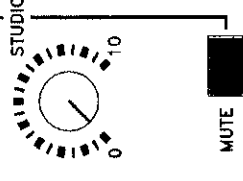
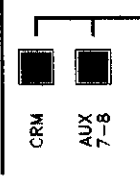
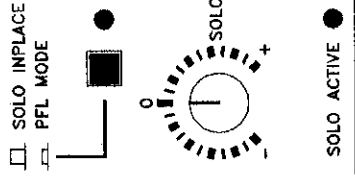
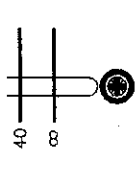
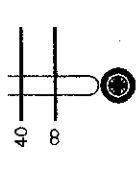
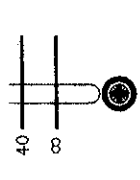

STUDIO

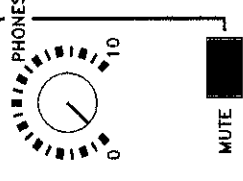
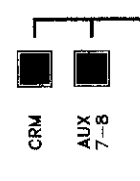
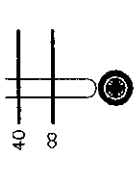

PHONES

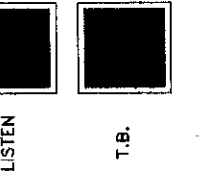
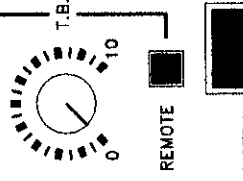
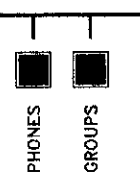
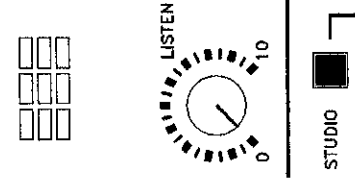
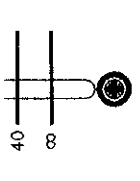

COMM

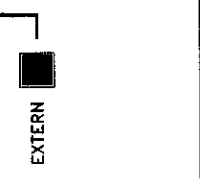
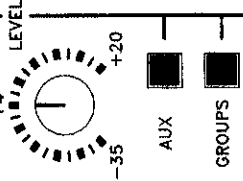
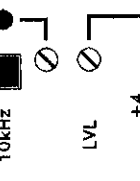
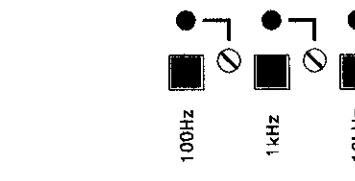
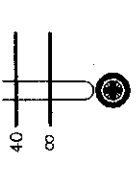

OSCILLATOR

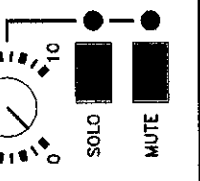
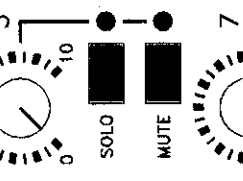
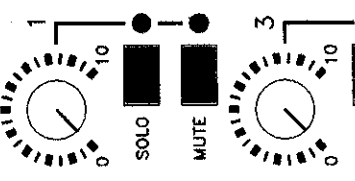
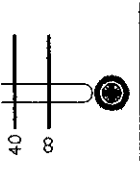

AUX

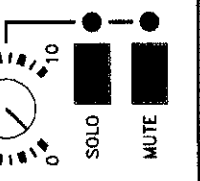
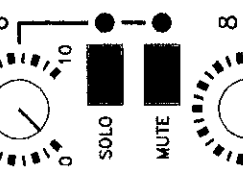
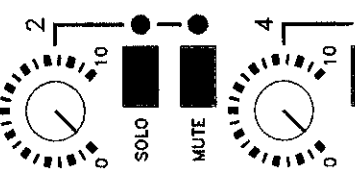
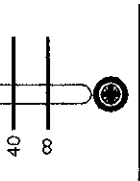

AUX

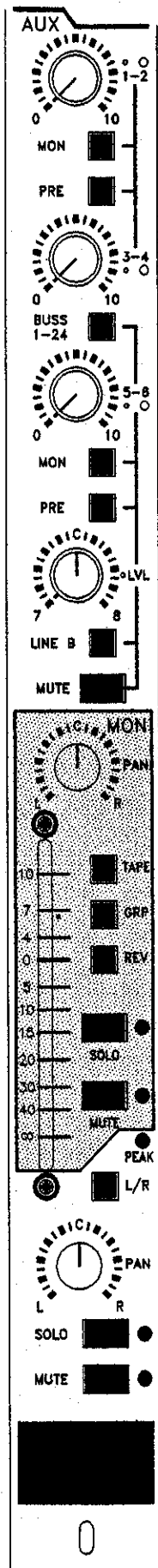
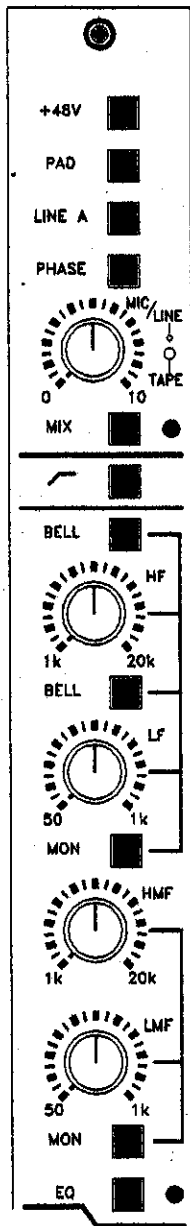

MARILON
channel in-line module

Dear Marilon owner,

In this manual we have tried to give you an overview of all that the Marilon series has to offer. If you have any questions, do not hesitate to contact us or the D&R USA customer support department. With the Marilon series there is no limit to your creativity. We wish you many years of enjoyable mixing.

Best regards,

Duco de Rijk
PRESIDENT D&R, HOLLAND

This manual was written by Duco de Rijk (D&R Holland) and Paul Westbrook (D&R USA). We hope you will find it to be useful and easy to understand. As ever, we are open to any suggestions about this manual or any D&R product.



**PATCHBAY
MULTIPIN WIRING**

"MARILON"

Martian

BY **DR**

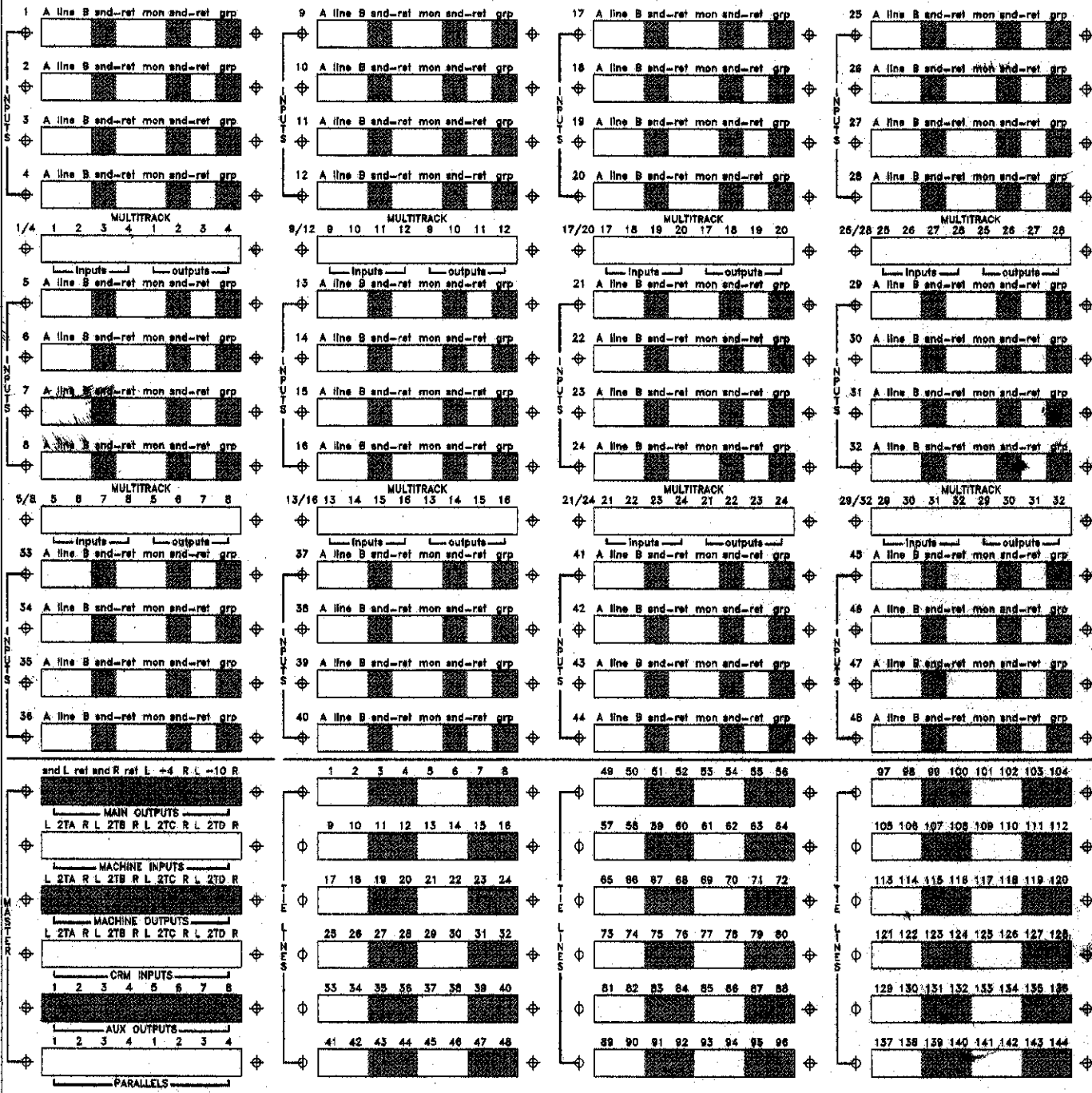

Marilon - 25D to Channel Connector

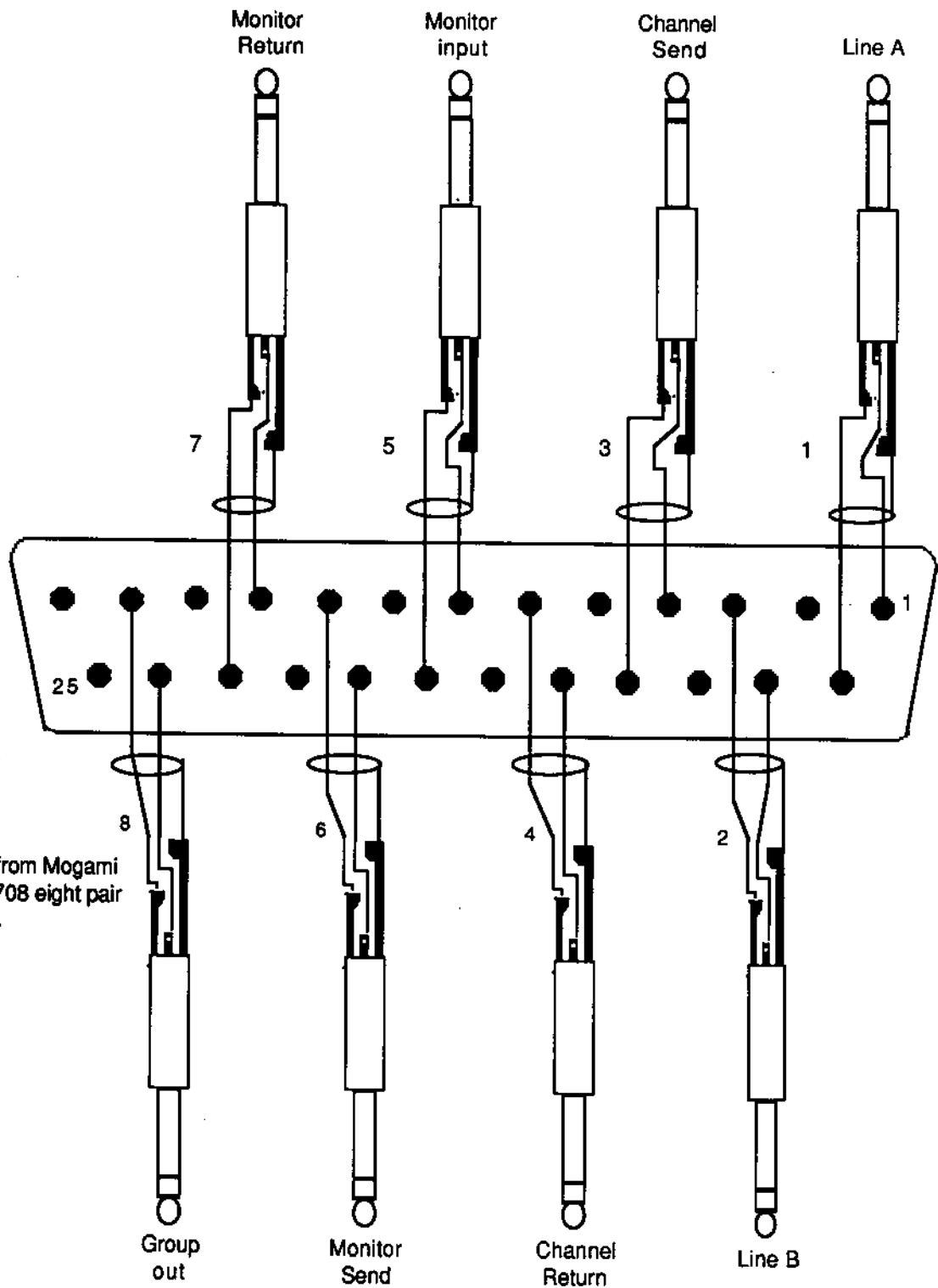

All shields lifted at 25 pin sub "D" connector and all shields are connected at 1/4" RTS sleeve.

Marilon - Main Outputs

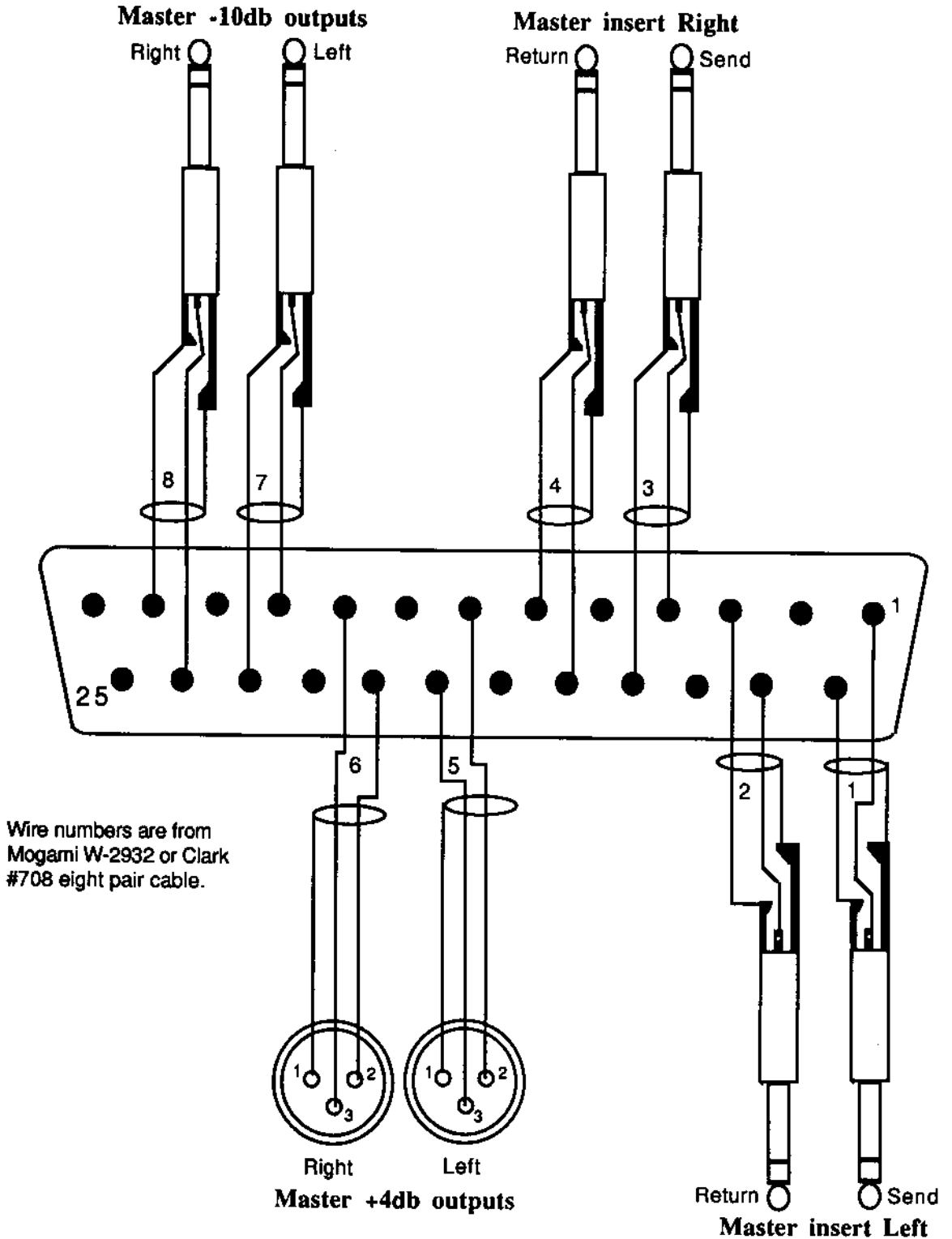

**All shields connected at 1/4" RTS (sleeve) and Male XLR connectors only.
All shields should be lifted at 25 pin sub "D" connector.**

Marilon - CRM Inputs

(MASTER SECTION)

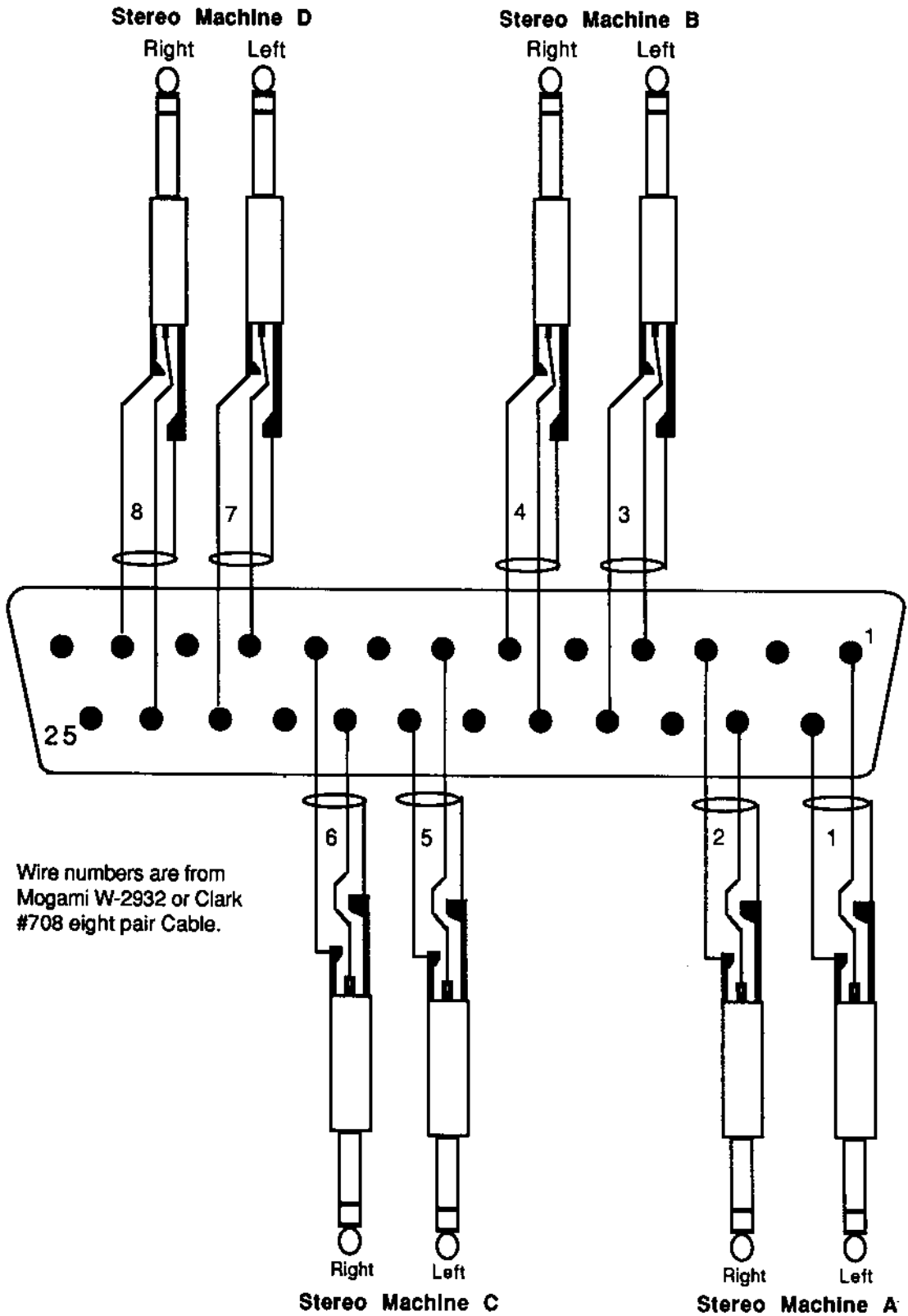

Wire numbers are from Mogami W-2932 or Clark #708 eight pair Cable.

All shields are connected at 1/4" RTS sleeves and lifted at 25 pin sub "D" connector.

Marilon - Aux Outputs 1 - 8

(MASTER SECTION)

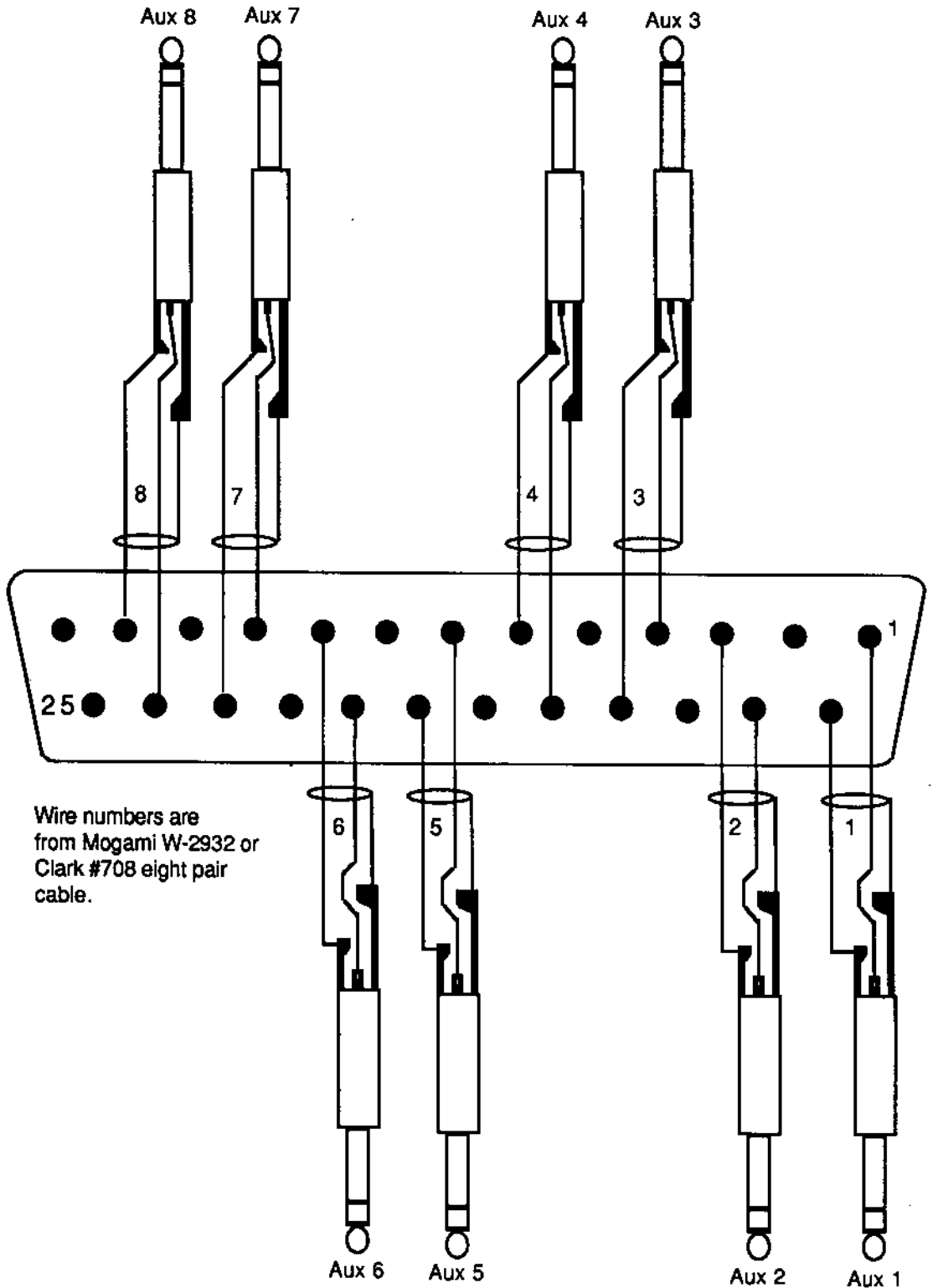

All shields are connected at 1/4" RTS sleeves and lifted at the 25 pin sub "D" connector.

Marilon - 25D to Multitrack Inputs and Outputs

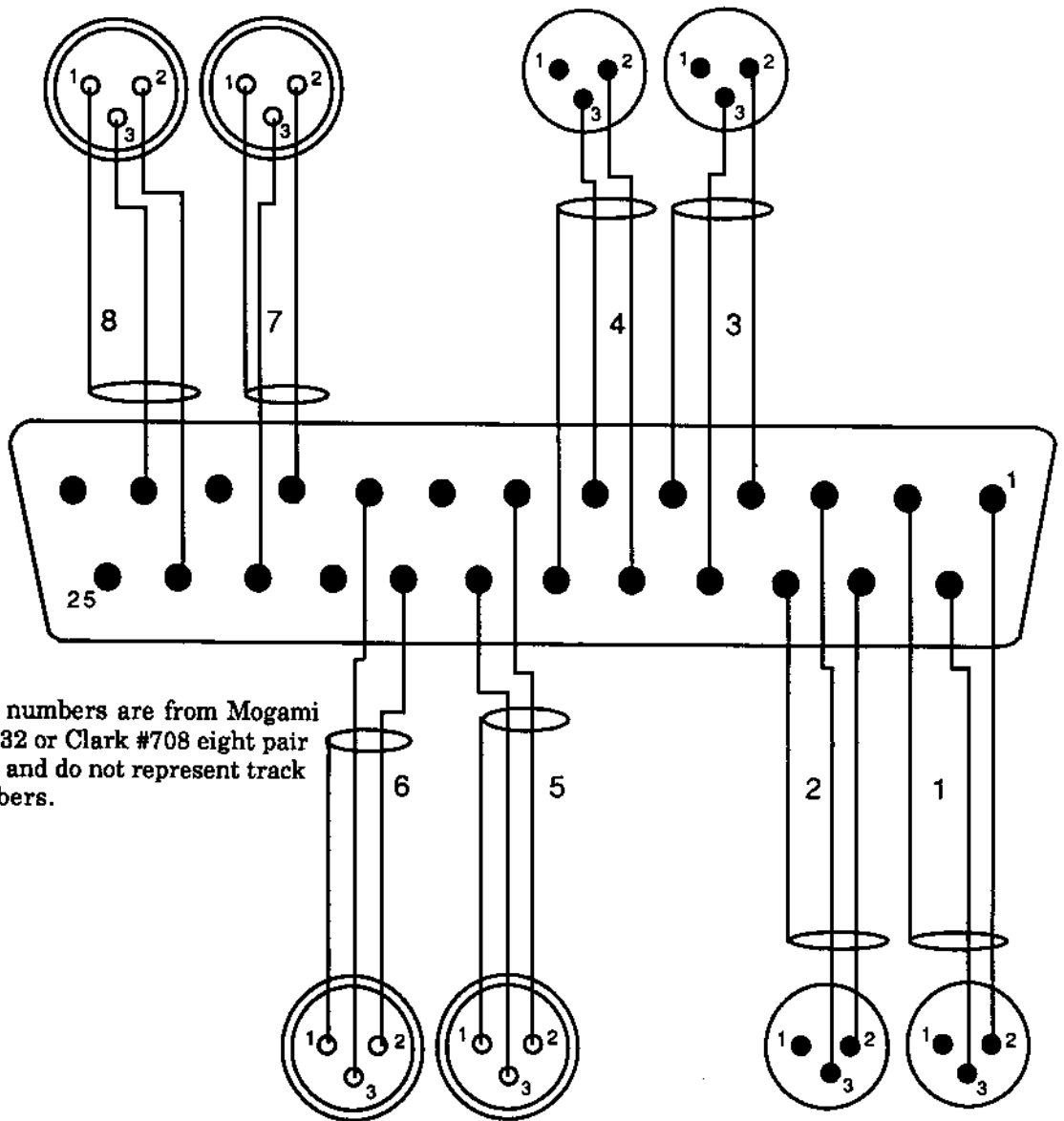

Wire numbers are from Mogami W-2932 or Clark #708 eight pair cable and do not represent track numbers.



Male XLR Connector

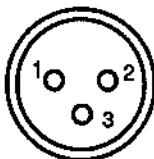

Female XLR Connector

Note: Shields are Lifted in Male XLR connectors and connected in Female XLR connectors in this harness.

Marilon - Tie Lines - Effects Inputs and Outputs

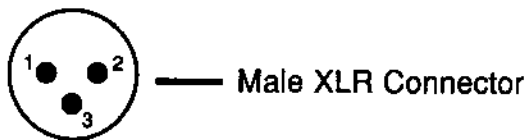
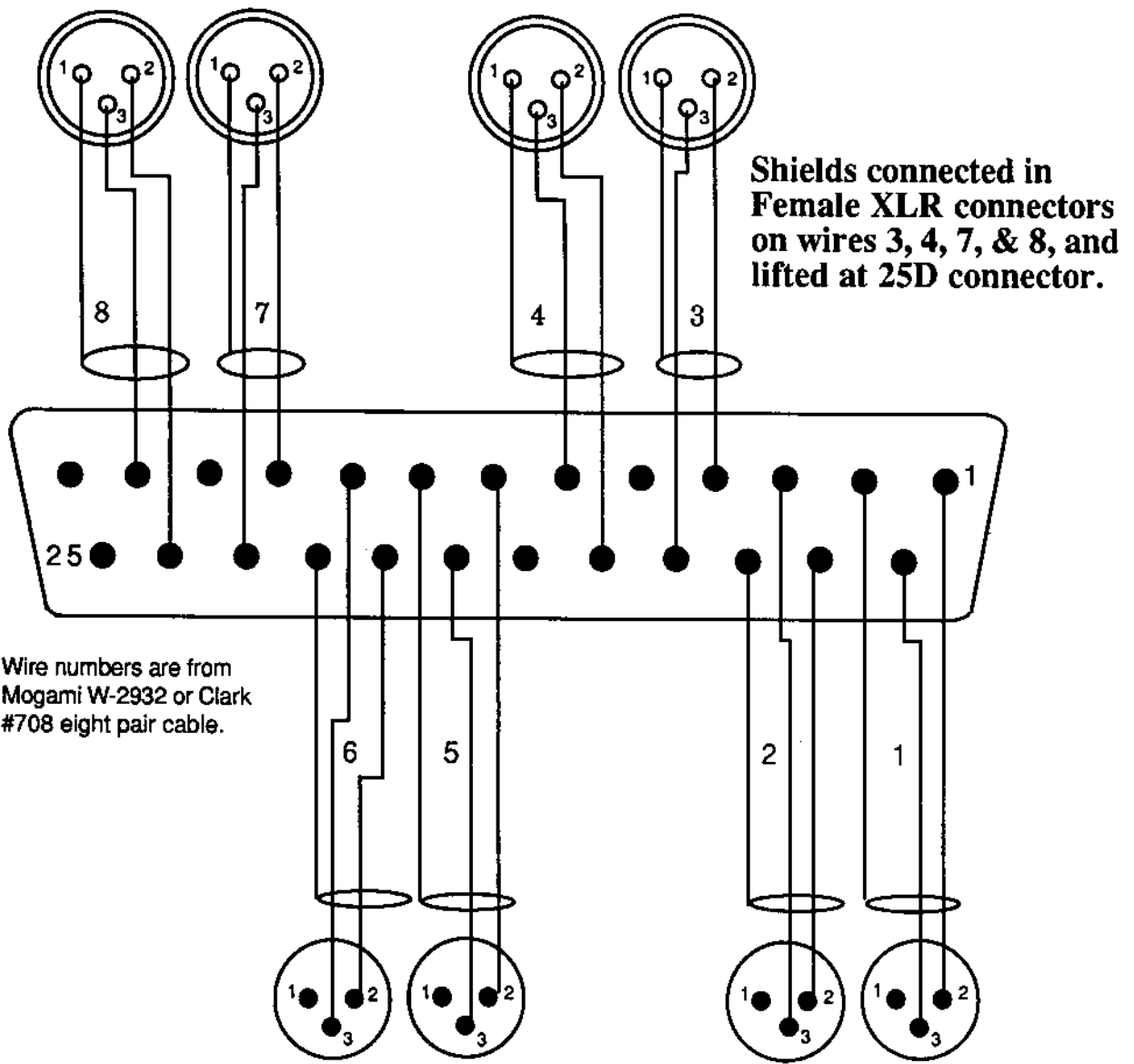

Shields lifted in Male XLR connectors on wires 1, 2, 5 & 6 and connected at 25D connector.

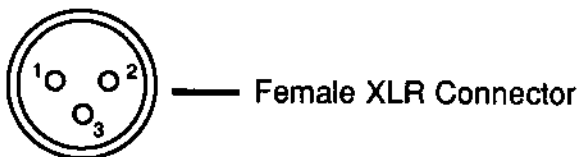

Note: Shields are lifted in Male XLR connectors and connected in Female XLR connectors.

Note: One cable harness as above is needed for each pair of stereo signal processing devices.

Marilon - 25D to Stereo Machine Inputs

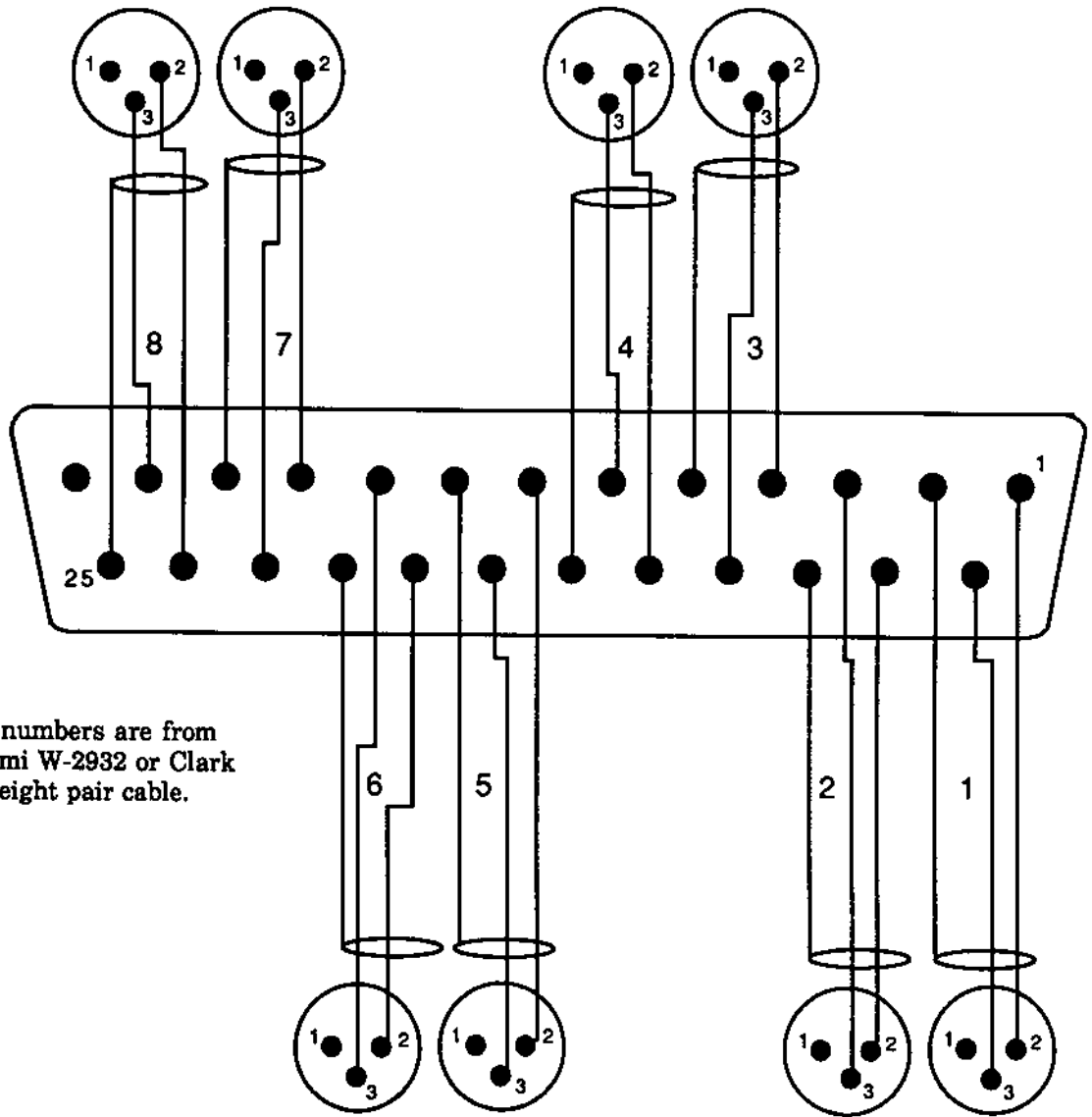

Wire numbers are from
Mogami W-2932 or Clark
#208 eight pair cable.

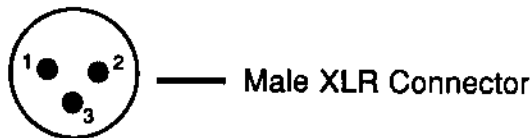

All shields lifted in Male XLR connectors and connected in 25 pin sub "D" connector and connected at 25D connector.

Marilon - 25D from Stereo Machine Outputs

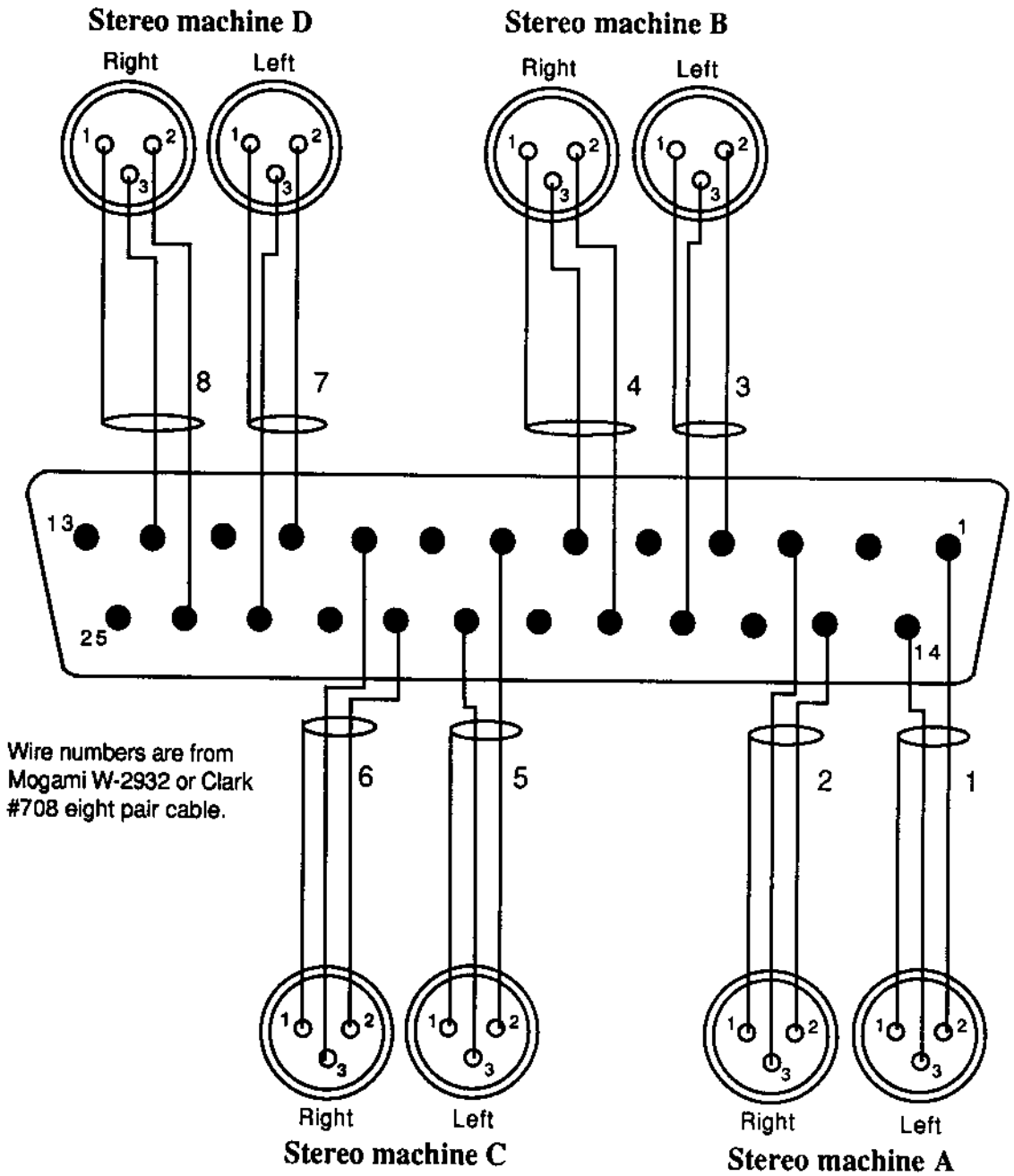

All shields lifted at 25 pin sub "D" connector and all shields connected at Female XLR connectors.

Marilon - Stereo Return Inputs

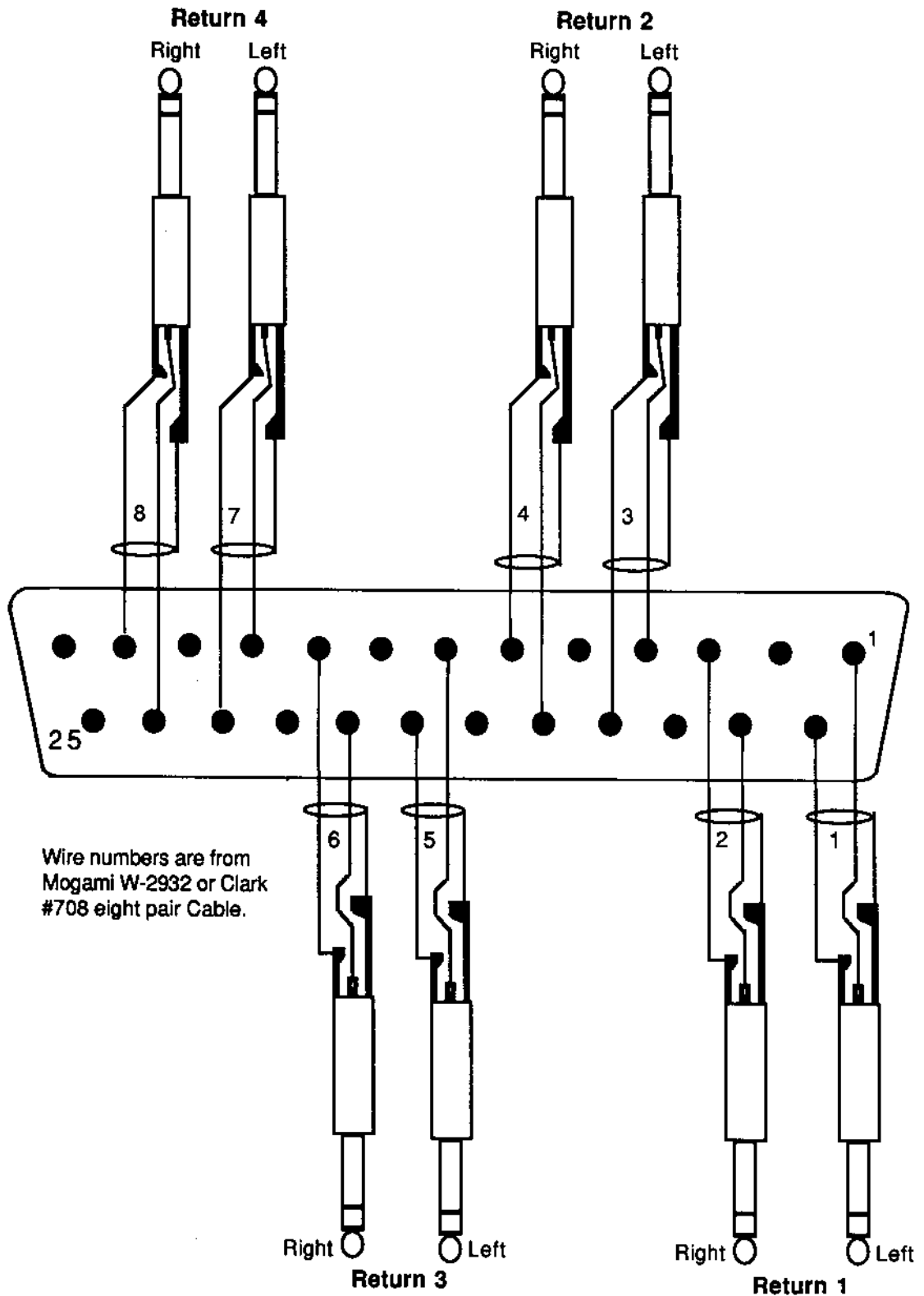

All shields are connected at 1/4" RTS sleeve only.
Note: This harness is connected between 4 stereo returns inputs and dedicated tie lines on patchbay back panel.