

"300 SERIE"

GEBRUIKSAANWIJZING

DNR

GEBRUIKSAANWIJZING

series 300

Zojuist heeft U een mengtafel van het merk D & R in ontvangst genomen. Deze mengtafel werd ontworpen door D & R ELECTRONICA in nauwe samenwerking met professionele gebruikers van mengpanelen. De gebruikte onderdelen zijn van hoge kwaliteit en staan in voor een lange levensduur en betrouwbare werking van Uw mengpaneel.

Wanneer na het bestuderen van deze handleiding nog vragen rijzen, aarzelt U dan niet contact met ons op te nemen, ook in geval van mogelijke storingen. Wij zullen al het mogelijke doen om U tot volledige tevredenheid te stemmen.

Wij wensen U een langdurig en creatief gebruik van dit mengpaneel.

BEDIENINGSORGANEN EN HUN FUNKTIES

MIC

De microfooningang van de 300 serie is standaard voorzien van XLR type connectoren zonder vergrendeling. De aansluiting van de microfoon behoort als volgt te geschieden.

Pin 1. aarde

Pin 2. in faze signaal

Pin 3. uit faze signaal

De microfooningang is geschikt voor symmetrische aansluiting van microfoons. Alleen deze vorm van aansluiten garandeert U een storingsvrije weergave. Asymmetrische of ongebalanceerde aansluiting is ook mogelijk, dan laat U Pin 3 vrij. Deze vorm van aansluiten heeft geen invloed op de versterking, alleen het stooronderdrukkingsvermogen van de elektronisch gebalanceerde mic-versterker wordt op deze wijze niet benut. Dus 2 binnenaders in Uw microfoonkabel betekent symmetrisch en 1 binnenader a-symmetrisch. De microfooningang is geschikt voor laag-ohmige microfoons met een impedantie van 200 - 600 Ohm.

LINE

Lijn niveau signalen (van taperecorders/versterkers) kunnen op de cinch connector aangesloten worden. Voorwaarde is wel dat de microfoonlijn schakelaar ingedrukt is. De lijningang is a-symmetrisch.

PHANTOME

Indien deze schakelaar gemonteerd is (het is een optie) zorgt hij in ingedrukte stand dat er 48 volt op punten 2 en 3 van de XLR plug staat, waardoor condensator microfoons zonder eigen voeding aangesloten kunnen worden. Voor dynamische microfoons heeft deze phantome voeding geen nadelige invloed, doch het is aan te raden deze uit te schakelen bij andere dan condensator microfoons.

GAIN

Deze knop zorgt voor de aanpassing van alle binnenkomende signalen aan het nominale niveau in de mengtafel wat 0 dBu is (0,775 Volt). Ieder signaal dat binnenkomt moet zo ingeregeld worden dat de kanaalfader in het gearceerde gebied gezet kan worden.

INSERTION

Deze stereo jack aansluiting heeft als doel U de mogelijkheid te geven om randapparatuur per kanaal aan te sluiten.

Wij hebben in ons programma een hele range geschikte randapparatuur zoals compressors, noise gates, parametrische equalizers etc., welke ideaal aanpassen op dit insertiepunt. Het insertiepunt is opgenomen na de equalizer.

De aansluiting is als volgt.

Tip:uitgaand signaal

Ring:terugkomend signaal.

Bij aansluiting van de stereo jack op een randapparaat zult U absoluut 2-aderig individueel afgeschermd kabel moeten gebruiken, daar anders de in- en uit-gang van het aangesloten apparaat in een afscherming liggen wat mogelijk oscillatie teweeg kan brengen. Geschikte kabel is bijvoorbeeld 2-aderig pick-up kabel. U kunt ook het insertiepunt gebruiken om een pre-fader signaal af te nemen zonder de signaalketen te onderbreken. U soldeert de top en de ring van de stereojack aan elkaar, samen met de signaal draad.

Ook een multitrack recorder kan eenvoudig aangesloten worden. De tip loopt naar de ingang van het tapedeck en de uitgang terug naar de ring. Nu kunt U direkt na band afluisteren.

TOONREGELING

Hoogregeling : De hoge tonen regeling heeft een zeer ruim regelbereik van + en - 18 dB bij 15.000 Hz. Het is wel zaak om deze extreme regelbaarheid met zorg te gebruiken. Indien U fors hoog ophaalt zonder dat voldoende program-informatie aanwezig is in dit gebied, zal dit resulteren in een toename van de grondruis welke wel versterkt wordt, terwijl het aanwezige signaal in een ander frequentiegebied zit.

De midden toonregeling heeft een regelbereik van ± 12 dB over een breed gebied met een centerfrequentie van 1000 Hz.

De lage toonregeling heeft een bereik van + en - 18 dB bij 50 Hz, wat ook betekent dat deze regeling met zorg bediend moet worden.

De gehele equalizer kan, indien U voor deze optie gekozen heeft, in en uitgeschakeld worden.

AUX

De Aux regelingen zijn bedoeld als extra regelingen van het signaal welke via somversterkers naar buiten komen.

Aux 1 is bedoeld om een onafhankelijke monitor / foldback mix te creëren. De niveaus van deze Aux 1 knoppen worden niet beïnvloed door de Fader-stand.

Aux 2 is na de fader aangesloten en dientengevolge wel afhankelijk van de fader stand. Deze Aux send is bedoeld om effect apparatuur zoals galm, echo, etc. op aan te sluiten. De verhouding tussen direkt signaal en het effect zal intact blijven bij verandering van de fader-stand.

PAN-POT

Onder de Aux 1/ 2 sends bevindt zich de panorama regeling welke U de mogelijkheid geeft het signaal van links via midden naar rechts te laten bewegen, waardoor met meerdere kanalen een "stereo beeld" ontstaat naar eigen inzicht en smaak.

PFL

De PFL toets biedt de mogelijkheid tot voor-afluistering van een kanaal zonder enige beïnvloeding van het signaal. Tevens is signaalniveau controle mogelijk op beide ledbars. Er kunnen meerdere solo toetsen tegelijk ingedrukt worden doch de niveau-indicatie is dan niet meer juist, daar de niveaus zich vanzelfsprekend optellen.

PEAK / NORMAL

De groene "normal" led (Licht Emitterende Diode) licht op zodra een signaal in het betreffende kanaal het juiste niveau bereikt heeft. De rode led (peak) licht op zodra het signaal een niveau bereikt heeft van +18 dB. Dit is 18 dB boven het nominale niveau en 4 dB onder het clippunt (vervormingsmoment). Hoewel er nog 4 dB over is voor er echt vervorming gaat optreden is het zeer aan te bevelen ervoor te zorgen dat deze leds slechts sporadisch oplichten. U moet deze leds echt zien als een duidelijke waarschuwing dat er een te hoog signaal heerst, waar U onmiddellijk iets aan moet doen wilt U niet te maken krijgen met vervorming. De groene led hoort regelmatig op te lichten.

VOLUMEREGELING

VOLUMEREGELING

Deze is uitgevoerd met een 60 mm schuif potentiometer.

STEREO KANALEN (OPTIE)

Het stereokanaal onderscheidt zich qua bediening niet van de monokanalen. Het is echter vanzelfsprekend dat de electronica geheel dubbel is uitgevoerd.

De XLR plug wordt nu de M.D.-ingang met een R.I.A.A.gecorrigeerde ingangstrap.

De aansluitingen zijn als volgt.

Pin 1. aarde

Pin 2. links

Pin 3. rechts.

Bij het gebruik van deze ingang moet U in verband met de gevoeligheid zorgen voor korte verbindingen naar het pick-up element. De cinch plug voor lijn signalen (tapedecks etc.) is nu een stereo jack geworden waarvan de tip de linkeringang vormt en de ring de rechteringang. Het insertiepunt is verdwenen bij stereokanalen, daar deze vaak reeds "ingeblikte" signalen geen nabehandeling behoeven. Ook de phantome toets zal altijd afwezig zijn. De eronder gelegen druktoets schakelt nu tussen de XLR plug (MD-ingang) en de stereo jack plug (stereo line ingang). Alle verdere bedieningsorganen blijven dezelfde functies behouden. Let op. Aux 1 en 2 mengen de links rechts informatie samen naar de uitgang. Ook de PFL is een sommatie van links en rechts en dus mono. De Pan-pot is nu balansregelaar geworden.

SOMGEDEELTE

Het somgedeelte bevat alle versterkers om de signalen uit de kanalen te sommeren en stelt ze via totaal volume regelaars aan de achterzijde beschikbaar. De beide faders zijn voor het totale links/rechts uitgangssignaal. De aansluitingen via cinch pluggen zijn dubbel uitgevoerd om meerdere apparaten gelijktijdig aan te kunnen sluiten. Zorg altijd dat de ingangsimpedantie van het aangesloten apparaat niet onder de 5 kOhm ligt. Er is tevens voorzien in 2 mono uitgangen waarvoor ook de 5 kOhm regel geldt.

De Aux 1 en 2 uitgangen zijn eveneens aan de achterzijde via cinch pluggen aan te sluiten. De totale volume-regeling vindt plaats via de Aux 1 en 2 volume-regelaars boven de linker master fader. De linker en rechter returns zijn bedoeld om een effect signaal (galm bijvoorbeeld) in te voegen bij het totaal signaal. De Aux 2 return left voor de linker master uitgang, de Aux 2 return right voor de rechter master uitgang. De knop waar alleen Aux 2 return bij staat mixt dit signaal bij de Aux 1 uitgang.

Direkt boven de linker master fader zit de ingangskeuzeschakelaar van de ledbars en de hoofdtelefoon. In de bovenste stand van deze druktoets hoort en ziet U het stereo som signaal, in de ingedrukte stand is het mogelijk om een eventuele ingedrukte pfl/afl toets te horen en te zien. Afl betekent trouwens after fade listening, wat betekent dat het niveau afhankelijk is van de totaal volume regelaars van de Aux 1 en 2. U kunt dan het niveau zien op de ledbars. Deze ledbars hebben een V.U.karakteristiek wat betekent dat ze een gemiddelde waarde aangeven van het signaal. Het 0-punt op deze ledbargraph betekent ook dat er dan 0 dBu (775 mV) aan de uitgang aanwezig is bij een constante sinus dan wel. Peaken kunnen wel 6 dB hoger liggen.

TAPE

TAPE

De tape toets is er om na band te kunnen luisteren wat er opgenomen is via een eventueel aangesloten stereo recorder. Om geen niveauverschillen te krijgen moet de aangesloten recorder niet verzwakken of versterken.

HEADPHONES

De koptelefoon aansluiting zit rechts onder op het front en is alleen geschikt voor koptelefoons van 400 Ohm en hoger.

TALKBACK

Op het front is voorzien in een "talkback" mogelijkheid. Dit is een XLR type plug waarop de gebalanceerde mic versterker aangesloten is. 1 is aarde, 2 infaze en 3 uitfaze. Via de talkback volumeregeling wordt het signaal, indien de toets erboven ingedrukt wordt, toegevoegd aan het Aux 1 signaal.

VOEDING

De netaansluiting is geschikt voor 220 Volt 50/60 Hz aansluiting. Indien de aan/uitschakelaar ingedrukt wordt zullen de onderste leds van de ledbar aan gaan ter indicatie dat de voedingsspanning aanwezig is. De netzekering zult U op de voedingsprint vinden na verwijdering van de bodem d.m.v. 6 bouten. De waarde is 1 Amp traag. Neemt U eerst de netstekker uit het stopkontakt.

OPTIES

In het geval Uw mengtafel uitgerust is met stereo kanalen veranderen de volgende zaken in het kanaal.

De microfoon XLR input wordt nu een stereo ingang welke geschikt is om magneto-dynamische elementen van pick-ups te versterken volgens de R.I.A.A.curve.

Aansluiting als volgt.

1. aarde
2. links
3. rechts.

De lijn omschakeling wordt eveneens stereo en is dan geschikt voor tape-decks, cassettedecks, jingle machines, etc. De aansluitingen zijn: huis - aarde. top - links. ring - rechts. De rest van de bedieningsorganen blijft dezelfde functies verzorgen als bij mono. Ter indicatie dat U stereokanalen heeft worden in de betreffende kanalen witte faderknoppen gezet.

FADER START SWITCHES

De schakelaars worden zo gemonteerd dat bij het infaden een microswitch geactiveerd wordt. De bedrading wordt in principe niet aangebracht daar dit teveel afhankelijk is van Uw gebruiks-situatie.

MUTE SCHAKELAAR

Met de mute schakelaar kunt U het signaal tijdelijk of blijvend afschakelen. Het signaal van het betreffende kanaal komt niet meer op de master links/rechts, en ook niet meer op Aux 1 en 2 uitgangen. De overload en voor-afluistering functies blijven echter in functie, evenals de send van het insertpunt.

TONE GENERATOR

Indien deze 1 kHz oscillator ingebouwd is verzorgt hij een 0 dB signaal op de links/ rechts en mono uitgangen indien de druktoets naast de talkback ingedrukt is.

AANSLUITINGEN VOOR P.A.-GEBRUIK

Sluit Uw microfoons als volgt aan:

- XLR pluggen 1. aarde
- 2. in faze
- 3. uit faze.

Gebruik bij voorkeur altijd symmetrisch aangesloten microfoons om minimale last van stoorsignalen te ondervinden.

Verbindt Uw P.A.-versterkers middels enkel-aderig afgeschermd kabel met de master outputs left/ right van de mengtafel. Het niveau is 0 dBu op de left/ right master outputs alsook op de Aux uitgangen. U moet erop letten dat de uitgangen niet onder de 1 kOhm belast worden. Bij recorder opnames wordt de recorder aangesloten op de master left en right uitgangen. Op de Aux 1 uitgang sluit U de Buhne monitor versterker aan (Foldback) terwijl Uw effect apparatuur aangesloten wordt tussen de Aux 2 send en returns.

De koptelefoon/monitor versterker wordt met de headphones jack verbonden.

IN GEBRUIKSTELLING

Zorg allereerst dat alle faders in hun ruststand staan bij het teken oneindig.

Gain potmeter op 0.

Toonregeling in de middenstand (0).

Aux sends 1/2 op 0.

Pan-pot in de middenstand.

Alle volumeregelingen in het somgedeelte eveneens op 0 (linksom).

Overtuig U van de juiste netspanning te weten 220 Volt 50/60 Hz.

Sluit de mengtafel aan op het lichtnet en schakel de netschakelaar in.

De onderste leds zullen nu oplichten ten teken dat er spanning aanwezig is.

INREGELING

Schuif de masterfader naar de stand 0 (maximaal dus).

Schuif eveneens een kanaalfader naar de "0"-stand in een kanaal waarop een microfoonsignaal aanwezig is.

Druk de master/ solo toets naar solo en druk tevens de solotoets in van het kanaal waarvan U de fader heeft opgeschoven.

Door de gain potmeter langzaam naar rechts te draaien zal de ledbar op gaan lichten. Het af en toe door de nulindicatie heenschieten van het signaal heeft geen gevolgen voor wat betreft oversturing in de mengtafel.

De toonregeling kan gebruikt worden indien nodig.

Let op.

Bij sterke ophaal van bepaalde frequenties wordt de versterking in het kanaal te groot en moet dit weer gecorrigeerd worden met de "gain" knop, daar anders oversturing kan optreden en de uitsturingruimte in het kanaal verkleind wordt.

U heeft nu 1 kanaal ingeregeld voor wat betreft niveau en klankkleur. Dit kunt U nu voor meerdere kanalen doen, waarna het eigenlijke mixen pas begint.

GARANTIEBEPALINGEN

D & R ELECTRONICA b.v. verplicht zich gedurende 1 jaar na aankoop alle defecten, optredend bij normaal gebruik, te verhelpen en alle kosten van materiaal en arbeidsloon voor haar rekening te nemen.

Onder geen enkele voorwaarde zal D & R ELECTRONICA b.v. verantwoordelijk gesteld kunnen worden voor welke schade dan ook, direkt dan wel indirekt veroorzaakt door haar produkten.

Wij wensen U nogmaals een plezierig gebruik !!!

product safety

This product is manufactured with the highest standards and is double checked in our quality control department for reliability in the "HIGH VOLTAGE" section.

CAUTION

- Never remove any panels, or open this equipment. No user servicable parts inside.
- Equipment power supply must be grounded at all times.
- Only use this product as described, in user manual or brochure.
- Do not operate this equipment in high humidity or expose it to water or other liquids.
- Check the AC power supply cable to assure secure contact.
- Have your equipment checked yearly by a qualified dealer service center.
- Hazardous electrical shock can be avoided by carefully following the above rules.

EXTRA CAUTION FOR LIVE SOUND

Ground all equipment using the ground pin in the AC power supply cable. Never remove this pin. Ground loops should be eliminated only by use of isolation transformers for all inputs and outputs. Replace any blown fuse with the same type and rating only after equipment has been disconnected from AC power. If problem persists, return equipment to **qualified service technician**.

Please carefully read the following information

Especially in sound equipment on stage the following information is essential to know. An electrical shock is caused by voltage and current, actually it is the current that causes the shock. In practise the higher the voltage the higher the current will be and the higher the shock.

But there is another thing to consider and it is resistance. When the resistance (in Ohms) is high between two poles, the current will be low and vice versa.

All three of these; voltage, current, and resistance are important in determining the effect of an electrical shock. **However, the severity of a shock is primarily determined by**

the amount of current flowing through a person.

A person can feel a shock because the muscles in a body respond to electrical current and because the heart is a muscle it can affect, when the current is high enough. Current can also be fatal when it causes the chest muscles to contract and stop breathing.

At what potential is current dangerous. Well the first feeling of current is a tingle at 0.001 Amp of current. The current between 0.1 Amp and 0.2 Amp is fatal.

Imagine that your home fuses of 20 Amp can handle 200 times more current than is necessary to kill. How does resistance affect the shock a person feels. Atypical resistance between one hand to the other in "dry" condition could well over 100,000 Ohm. **If you are playing on stage your body is perspiring profusely and your body resistance is lowered by more than 50%. This is a situation in which current can easily flow.** Current will flow when there is a difference in ground potential between equipment on stage and in the P.A. system.

Please do check if there is any potential between the housing of the mikes and the guitar/synth amps, which will be linked by your body on stage. Imagine, a guitar in your hand and your lips close to the mike! A ground potential difference of above 10 volts is not unusual, in improperly wired buildings it can possibly be as high as 240 volts. Although removing the ground wire sometimes cures a system hum, it will create a very hazardous situation for the performing musician.

Always earth all your equipment by the grounding pin in your mains plug. Hum loops should only be cured by proper wiring and isolation input/output transformers.

Replace fuses always with the same type and rating after the equipment has been turned off and unplugged. If the fuse blows again you have an equipment failure, do not use it again and return it to your dealer for repair.

And last but not least Be carefull not to touch a person being shocked as you, yourself could also be shocked. Once removed from the shock, have someone send for medical help immediately.

Always keep the above mentioned information in mind when using electrically powered equipment.

"300 SERIES"

USER MANUAL

DNR

INSTRUCTION MANUAL OF THE D&R SERIES 300 AUDIO MIXER

The D&R mixer, you just have bought, will offer you outstanding performance during a long period. We warrant our series 300 audio mixers will be free from defect in materials and workmanship, under normal use and service, for a period of one (1) year, from date of delivery, when properly installed. D&R will repair and/or replace any defective part of the desk that has come to fail under normal use for a period of one year, from date of delivery. Under no circumstance D&R will be held liable for any other damage, either direct or consequential.

The series 300 is designed to act as an 8 into 2 mixer, suitable for various applications, such as: broadcast, video postproduction, keyboard- and microphonemixing and so on. To become familiar with all the possibilities offered, we suggest you to read this manual carefully. Then you will be able to obtain the best results from your series 300.

CONTENTS OF THIS MANUAL

1. Description of a channel
2. Description of the mastersection
3. Wiring
4. Specifications

1 DESCRIPTION OF A CHANNEL

MIC

The mic input of the series 300 is standard provided with a XLR plug, without lock. You should connect it as follows:

Pin 1 - Earth

Pin 2 - Inphase signal

Pin 3 - Outphase signal

As a result of the XLR input, the mic input will accept symmetrical connection of the microphone. Only this type of connection guarantees you a noise and interference free result, because you use the noise-reduction capability of the electronically balanced input amplifier. So, two two innerleads in you microphonecable mean symetrical and one innerlead means asymetrical. The mic input will accept low impedance microphones from 200 up to 600 Ohm.

LINE

Line level signals, such as tapedecks, keyboards, amps and so on, are to be connected to the cinchplug at the rear side of the mixer. You have to press the mic/line switch. The line input is asymetrical wired.

PHANTOM

When this optional switch is fitted, you are able to provide phantom power to condenser microphones, which need external powering. Pin 2 and 3 deliver 48 Volt phantom power. Phantom power does not affect dynamic microphones, although it is advisable to shut it off when other microphones then condensers are used.

GAIN

The gain adapts every incoming signal to the nominal level of the mixer, which is 0 dBu, 0,775 V. In order to put the channelfader in the marked area, you have to adjust every incoming signal to noise ratio possible.

INSERTION

This stereojack is fitted in order to give you the possibility of connecting ancillary equipment per channel.

D&R offers you a whole range of signal processors, such as compressors, noise gates, parametric equalizers and so forth, which perfectly suit the insertion point. Ofcourse other brands are also compatible, but compare the specifications of your ancillary equipment and the series 300 mixer carefully.

The connection is as follows:

Tip of the jack - outgoing signal from the mixer

Ring of the jack - incoming signal to the mixer

On connecting the stereojack you have to use individually shielded phonocable; otherwise oscillation may appear.

You can also use the insertionpoint for taking off a prefader signal. You only have to solder the top and the ring of the stereojack together with the signalwire. A multitrack recorder too, can easely be connected. The tip of jack has to be connected with the input of the recorder, and the ring with the output of the recorder. Now you have the possibility of direct tapemonitoring.

TONE CONTROL

Treble - this control has a very large range of ± 18 dB at 15 kHz. However if you boost treble without sufficient program information, only noise will then be boosted.

Mid - this control has a range of ± 12 dB at 1 kHz.

Bass - this control has a range of ± 18 dB at 50 Hz. This means that you have to handle with care too.

AUX

The aux sends are intended to act as extra controls for the signals which come out through the summing amps.

Aux 1 is for creating an independent foldback/monitormix. The level of these aux 1 controls are not being influenced by the channelfaderposition.

Aux 2 is after fader wired, and therefore dependent from the channelfaderposition. On this aux send you can connect effectdevices, such as delay or flanging. The relation between direct signal and effect signal will remain the same after altering the faderposition.

PFL

PFL stands for prefader listening, which means that you monitor a channel without influencing it. Also levelcontrol on both ledbars is possible. Several PFL switches can be pushed on simultaneously, although the levels on the ledbar are not correct any longer as they add.

PANPOT

Right under the aux 1/2 sends you will find the panpot control. It gives you the opportunity of moving a signal from left to right, via the center. Thus creating a stereoimage of your own taste.

PEAK/NORMAL LED

The green 'normal' led will light as a signal reaches the nominal level of the mixer, in that specific channel. The red 'peak' led will light when the signal has reached a +18 dB level. This is 18 dB above the nominal level, and 4 dB before clipping will occur. Although 4 dB is left before distortion will appear, it is advisable that this led will light up sporadic.

These red leds are meant as a warning for dangerous signal levels, with which you have to deal immediately. The green led should light up regularly.

TONE CONTROL

Treble - the treble control has a very large range of ± 18 dB at 15.000 Hz. It is important to use it with care. If you boost treble without sufficient program-information, the result will be high level noise, as the program information is present in another frequency area.

Mid - the midrange control has a range of ± 12 dB, centered at 1.000 Hz, but well-spreaded.

Bass - the bass control has a range of ± 18 dB at 50 Hz, which means that you have to boost or cut with care too.

The whole equalizersection may be switched off, but that is an option.

AUX

The aux sends are meant as extra controls for the signal going out through the summingamplifiers.

With aux 1 you are able to create an independent monitor/foldback mix. The aux 1 level is not influenced by the faderposition.

Aux 2 is postfader wired, and therefore dependent from the faderposition. It is fitted for connecting effectdevices, such as delay, phasing etc. The aux 2 signals return in the mastersection. See also chapter 2 and 4 of this manual.

VOLUME CONTROL

This fader controls the overall volume after the gain. You use it to mix all the signals together. We have fitted a high quality 60 mm potentiometer.

STEREOCHANNELS

The optional stereochannels do not differ from the normal mono channels. Ofcourse the PCB's and all the electronics are doubled. The following differs from a standard mone channel:

1. The XLR plug becomes a MD input with a RIAA corrected input stage. You should connect it as follows:

Pin 1 - earth

Pin 2 - left

Pin 3 - right

On using this input you should use short connecting leads, in view of capacitance and sensitivities.

2. The cinch plug for line signals becomes a stereojack. You use this stereojack for connecting line level signals, with the following wiring:

Top of the jack - left

Ring of the jack - right

3. The insertion point is no longer fitted, as these pre-recorded signals do not need any external signal processing.

The RIAA/Line pushbutton switches between the XLR plug (MD input) and the stereo jackplug (line input). All other functions remain the same.

IMPORTANT: Aux 1 and aux 2 mix the left-right information together to the output. The PFL too is the sum of left and right and therefore mono. The panpot become a balance control.

2. DESCRIPTION OF THE MASTERSECTION

SUMMING PART

The summing part contains all the amplifiers for summing the signals from the channels together. They leave the mixer at the rear side via the total volume controls. Both faders are for the left/right output signal.

The connections at cinch have been fitted double, in order to connect several devices at the same time. Take care of the input impedance of the apparatus connected; it should not be under 5 kOhm. This rules for the two mono cinch outputs too. The aux 1 and 2 outputs are to be found at the rear side at cinch too. You control the volume with the aux 1 and aux 2 volume controls, above the left master fader. The left- and right-aux returns are meant for adding an effect signal - a delay for instance - at the master signal. The knob marked with aux 2 mixes this signal together with the signal at the aux 1 output.

Direct above the left master fader you will find the input selector of the led bars and headphones. The upper position of this push button gives you the stereo sum signal. When this button is pressed, you are able to monitor a pressed pfl/afl button. In fact you can monitor a single channel.

AFL stands for after fade listening, which means that the level is dependent from the total volume controls of aux 1 and 2. You can watch the level on the led bars. The led bars do have a VU characteristic, which means that they indicate the average value of the signal. The 0 dB point at the scale means that 0.775 Volt (= 0 dBu) is available at the output. That is measured with a constant sinus, peaks may have a 6 dB higher level.

TAPE

The tape button is fitted for after tape listening, when you have connected a stereo taperecorder. The recorder connected must not attenuate nor gain, in order to get no level differences.

HEADPHONES

The headphone connection is fitted right under at the front. It is only suitable for high impedance headphones of 400 Ohms or higher.

TALK BACK

At the front we have provided a talk back. It contains of a XLR plug on which the balanced microphone-amplifier is connected. The connection is as follows: Pin 1 - earth, Pin 2 - in phase, Pin 3 - out phase

Via the talkback control the microphone signal will be added to aux1, if you do press the button.

MAINS

The mixer will work properly on 220 Volt, 50/60 Hz. The first led of the led bar will always light, as a power on indication.

The fuse is to be found at the mains print, after removing the bottom with 6 screws. **IMPORTANT: DISCONNECT THE MAINS PLUG!!!**

3 D&R SERIES 300 WIRING

In order to make all the connections clear for you, we have made a wiring diagram for you. You will find a mono channel - thin lines - and a stereo input channel - bold lines. The arrows stand for the connections you have to make.

Of course mono channels are single wired, and stereo channels are double wired. The plugs used, and the connections for it, are stated below.

In the master section you will find two stereo-outputs and two mono-outputs. In this example we have used one stereo-output for connecting a taperecorder, and one stereo-output for connecting a power amplifier. You may use the extra mono-outputs for various applications, for instance a light organ. The signal coming from the taperecorder (tape out) returns left from the aux 1/2 outputs, at tape l/r.

Aux 1 is prefader wired, and therefore aux 1 is meant as a monitor output. In this example we have connected it with a monitor amplifier. Aux 2 is a postfader wired effectsend. It returns at the effect returns left and right.

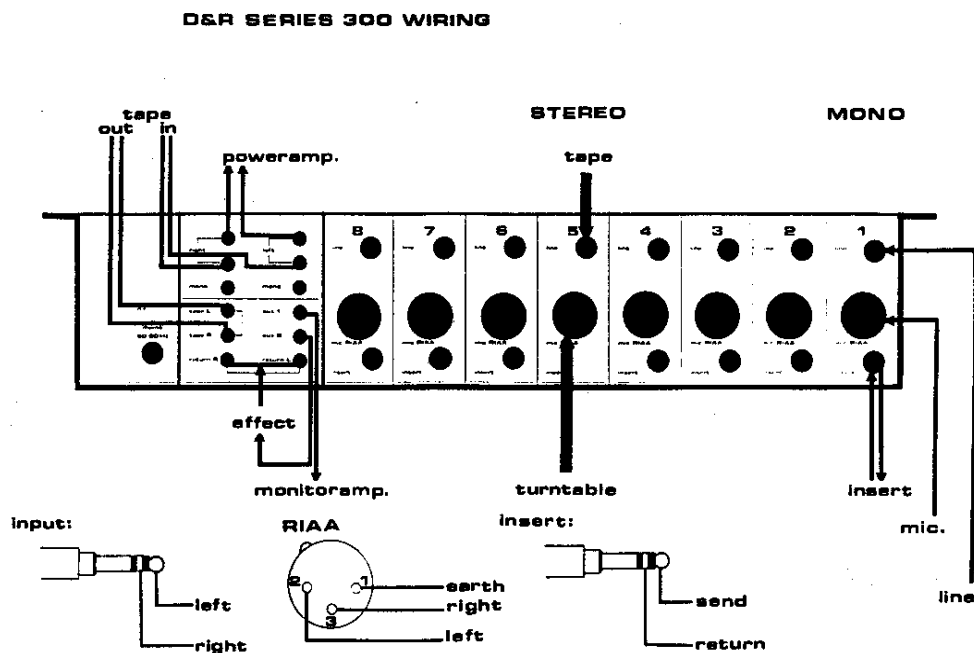

4 TECHNICAL SPECIFICATIONS

TECHNICAL SPECIFICATIONS

Inputs mic balanced 2 kOhm via female XLR

CMMR at 50 Hz -70 dB

line unbalanced 10 kOhm via cinch

insert 0 dBu level 100 Ohm/10 kOhm impedance via stereo breakjack

min/max mic input sensitivity: -70 dBu to -30 dBu for 0 dBu out

min/max line input sensitivity: -20 dBu to infinity

aux returns -20 dBu at 10 kOhm

tape returns 0 dBu at 10 kOhm

Outputs left/right/mono/aux1,2: 0 dBu at 100 Ohm

Noise mic input at max gain: -126,5 dB 20 - 20.000 Hz

output noise master faders down: -92 dBu

output noise master faders up: -80 dBu

Frequencyresponse: 20 - 20.000 Hz $\pm 0,25$ dB, at 80.000 Hz -3 dB

Equalisation ± 18 dB at 15.000 Hz shelve (± 16 dB at 10.000 Hz)

± 12 dB at 1.000 Hz bell

± 18 dB at 50 Hz shelve (± 16 dB at 70 Hz)

Overall total harmonic distortion less than 0,039%

max gain through desk 76 dB incl. postfader gain of 6 dB

Dimensions 483 x 345 x 95 mm

Weight without packing 6.5 kg

List of used integrated circuits:

Exar NE 5534

Texas Instruments TL 071

TL 072/082

TL 074/084

Telefunken UA 180 led bar driver

Fairchild 7815

7915

Pin compatible replacement IC's:

original

TL 071

TL 072

TL 074

replacement

TDA 1034

TDA 1032

NE 5532

LF 356

LF 347

lower quality replacement

TL 081/UA741

TL 082/UA 1458

UA 4741/4212/LM 324

"300 SERIES"

SERVICE MANUAL

DNR

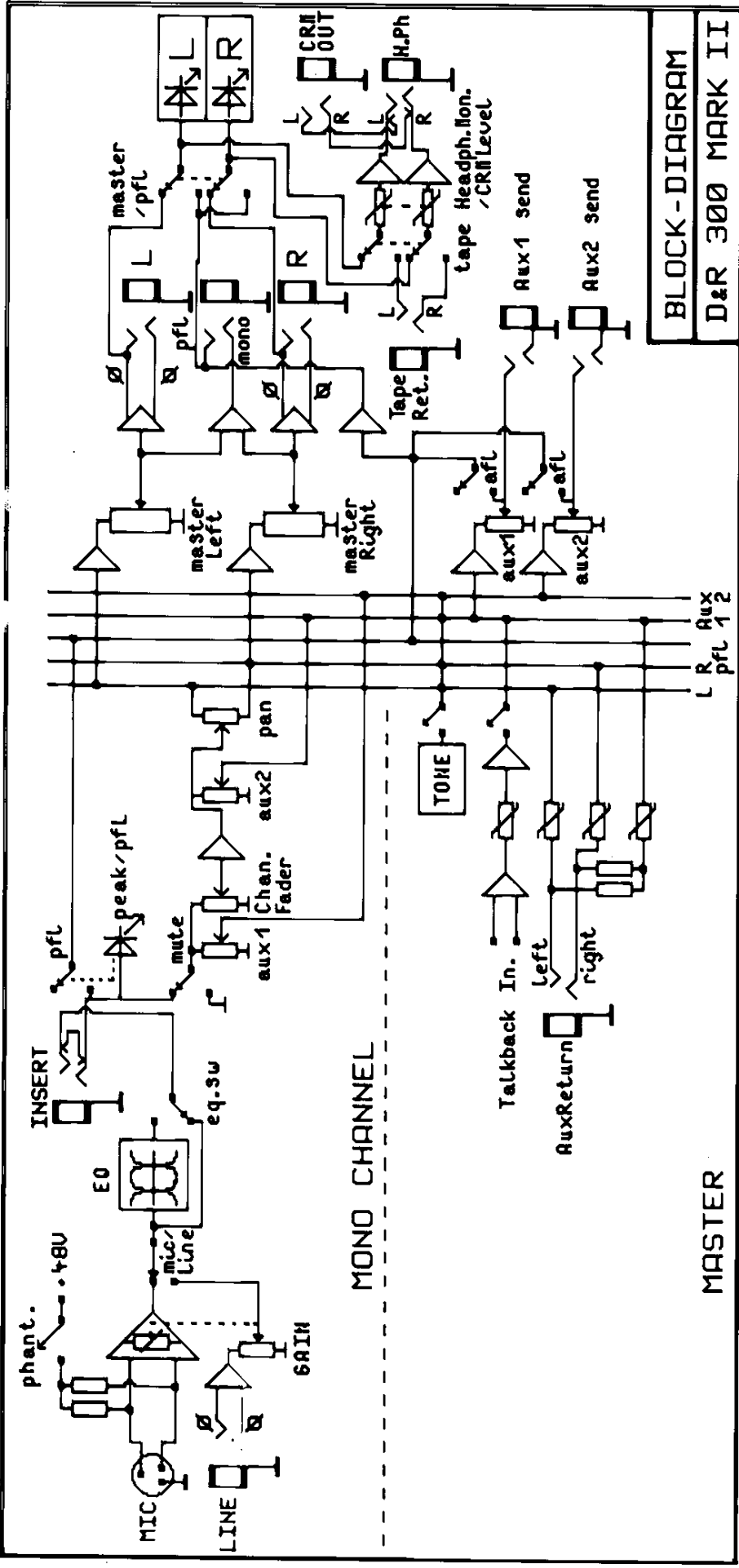

BLOCK-DIAGRAM
D&R 300 MARK II

TELEX: 18503 dr nl
TELEPHONE: 02940-18014
RIJNSKADE 15b
1382 GS WEESP
Electronica by Holland

TITLE :
PCB REF. nr.
DESIGN :
DATE :
SHEET

THIS DRAWING REPLACES PREVIOUS ONES

| | |
|----------|--|
| INDEX | |
| MOD. BY. | |
| DATE | |
| CHECK 1 | |
| CHECK 2 | |
| DRAWN | |

NOTES

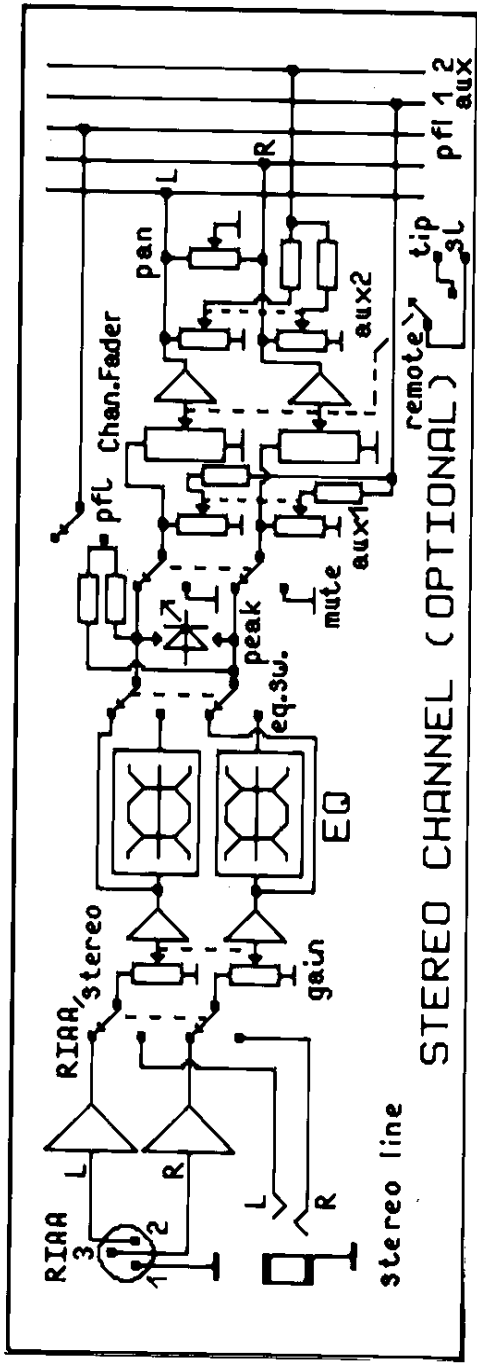

STEREO CHANNEL (OPTIONAL)

TELEX: 18503 dr nl
 TELEPHONE: 02940-18014
 RIJNKADE 15b
 1382GS WESP
 Electronica by Holland

TITLE :
 PCB.REF.nr.
 DESIGN
 DATE
 SHEET OF

THIS DRAWING REPLACES PREVIOUS ONES

| | |
|---------|--|
| INDEX | |
| MOD.BY. | |
| DATE | |
| CHECK 1 | |
| CHECK 2 | |
| DRAWN | |

NOTES



Rijnkade 15b
1382 GS REESP
TLX. 18583 dr nl
TEL. 02940-18814

Date : 16-09-1987

R & D department

PARTLIST : 300-1 MONO CHANNEL mark2

print index: g / h

| | PartNr | Value | Notes | PartNr |
|--------|--------|--------|-------|--------|
| mic | R1 | 6 k 81 | 1% | 0846 |
| | R2 | 6 k 81 | 1% | 0846 |
| | R3 | 10 k | 5% | 0741 |
| | R4 | 3 k 9 | 5% | 0736 |
| | R5 | 3 k 9 | 5% | 0736 |
| | R6 | 10 E | 5% | 0705 |
| | R7 | 10 E | 5% | 0705 |
| | R8 | 4 k 7 | 5% mf | 0801 |
| | R9 | 4 k 7 | 5% mf | 0801 |
| | R10 | 8 k 2 | 5% mf | 0802 |
| | R11 | 8 k 2 | 5% mf | 0802 |
| | R12 | 22 E | 5% | 0709 |
| | R13 | 82 k | 5% | 0752 |
| | R14 | 47 k | 5% | 0749 |
| line | R16 | 1 k 2 | 5% | 0730 |
| | R17 | 6 k 8 | 5% | 0739 |
| | R18 | 82 k | 5% | 0752 |
| | R19 | 47 k | 5% | 0749 |
| eq. | R20 | 10 k | 5% | 0741 |
| | R21 | 10 k | 5% | 0741 |
| | R22 | 47 k | 5% | 0749 |
| | R23 | 10 E | 5% | 0705 |
| | R24 | 10 E | 5% | 0705 |
| | R25 | 18 k | 5% | 0744 |
| | R26 | 10 k | 5% | 0741 |
| | R27 | 10 k | 5% | 0741 |
| | R28 | 10 k | 5% | 0741 |
| | R29 | 1 M 0 | 5% | 0765 |
| | R30 | 1 M 0 | 5% | 0765 |
| | R31 | 47 k | 5% | 0749 |
| | R32 | 100 E | 5% | 0717 |
| pfl | R33 | 10 k | 5% | 0741 |
| aux 1 | R34 | 47 k | 5% | 0749 |
| fader | R35 | 10 k | 5% | 0741 |
| | R36 | 1 k 0 | 5% | 0729 |
| | R37 | 10 k | 5% | 0741 |
| | R38 | 22 k | 5% | 0745 |
| pan | R39 | 6 k 8 | 5% | 0739 |
| | R40 | 6 k 8 | 5% | 0739 |
| | R41 | 47 k | 5% | 0749 |
| | R42 | 47 k | 5% | 0749 |
| aux 2 | R43 | 10 k | 5% | 0741 |
| | R46 | 100 k | 5% | 0753 |
| | R47 | 22 k | 5% | 0745 |
| | R48 | 1 k 0 | 5% | 0729 |
| supply | R49 | 10 E | 5% | 0705 |
| | R50 | 10 E | 5% | 0705 |
| | R51 | 10 E | 5% | 0705 |
| mic | R52 | 82 k | 5% | 0752 |
| | R53 | 47 k | 5% | 0749 |
| | R54 | 47 k | 5% | 0749 |
| | R55 | 47 k | 5% | 0749 |
| | R56 | 47 k | 5% | 0749 |

| | | | | |
|---------|-----------------------|--------------|----------------------|------|
| mic | C1 | 47 / 63 | elco | 0289 |
| | C2 | 47 / 63 | elco | 0289 |
| | C3 | 270 p | ker | 0230 |
| | C4 | 220 / 16 | elco | 0301 |
| | C5 | 47 / 25 | elco | 0287 |
| | C6 | 47 / 25 | elco | 0287 |
| | C7 | 4 p 7 | ker | 0209 |
| | C8 | 4 p 7 | ker | 0209 |
| | C9 | 47 / 25 | elco | 0287 |
| line | C10 | 47 / 25 | elco | 0287 |
| | C11 | 270 p | ker | 0230 |
| | C12 | 4 p 7 | ker | 0209 |
| | C13 | 47 / 25 | elco | 0287 |
| eq. | C14 | 0.022 | poly | 0256 |
| | C15 | 1000 p | poly | 0246 |
| | C16 | 0.01 | poly | 0253 |
| | C17 | 6800 p | poly | 0251 |
| | C18 | 47 / 25 | elco | 0287 |
| fader | C19 | 47 / 25 | elco | 0287 |
| | C20 | 270 p | ker | 0230 |
| | C21 | 22 p | ker | 0217 |
| | C22 | 47 / 25 | elco | 0287 |
| leddr | C23 | 47 / 25 | elco | 0287 |
| supp ly | C24 | 47 / 25 | elco | 0287 |
| | C25 | 47 / 25 | elco | 0287 |
| | C26 | 0.1 / 63 | ker | 0241 |
| | C27 | 47 / 25 | elco | 0287 |
| | C28 | 0.1 / 63 | ker | 0241 |
| mic | T1 | BC 560 | PNP | 0327 |
| | T2 | BC 560 | PNP | 0327 |
| | T3 | BC 560 | PNP | 0327 |
| | T4 | BC 560 | PNP | 0327 |
| | T6 | BC 546 | NPN | 0328 |
| | T7 | BC 546 | NPN | 0328 |
| | A1-A4 | TL 074 | bifET | 0305 |
| | A5 | TL 071 | bifET | 0303 |
| mic | D1 | 5 V 6 | zener | 0351 |
| | D2 | 5 V 6 | zener | 0351 |
| | D3 | 5 V 6 | zener | 0351 |
| | D4 | 5 V 6 | zener | 0351 |
| | D6 | 1N4148 | sgn | 0342 |
| | D8 | LED 5 x 2 mm | red | 0390 |
| mic | P1 | 10 kCB | 15mm stereo | 0106 |
| eq. | P2-P4 | 100 kA | 15mm mono | 0113 |
| aux 1 | P5 | 10 kB | 15mm mono | 0104 |
| aux 2 | P6 | 10 kB | 15mm mono | 0104 |
| pan | P7 | 10 kA | 15mm mono | 0103 |
| | F1 | 10 kB | ALPS 100mm mono | 0102 |
| | S1-S4 | 2 x 2 | FOX | 0400 |
| mute | S5 | 2 x 2 | FOX | 0400 |
| remote | S6 | startswitch | (optional) 0407/0410 | |
| mic | J1 | XLR 3 pin | fem.plast. | 0427 |
| line | J2 | jack stereo | CLIFF plast | 0433 |
| insert | J3 | jack break | CLIFF plast. | 0432 |
| remote | J4 | jack mono | 3.5mm (optional) | 0431 |
| | CONN1 (only in mk2) | 0.1" 17 pins | MOLEX 4030 | 0900 |

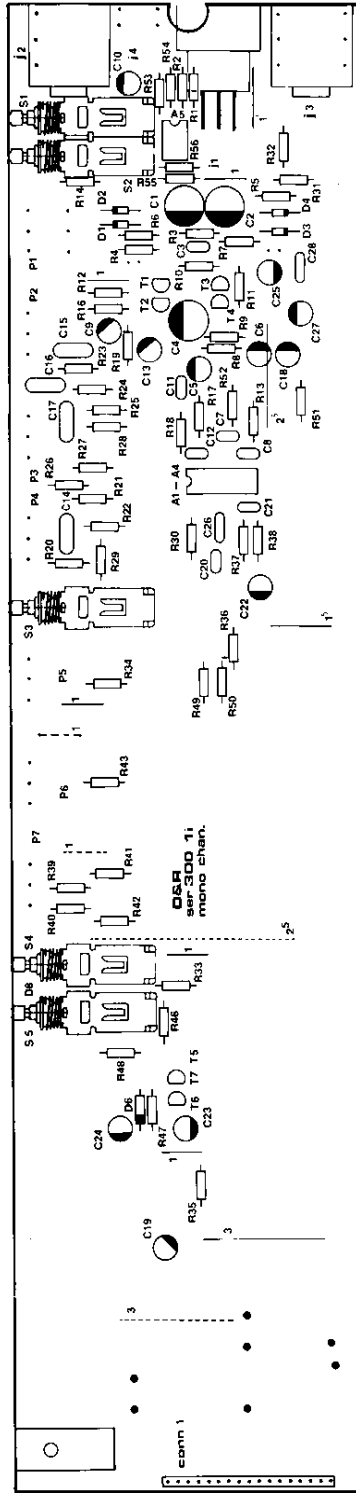
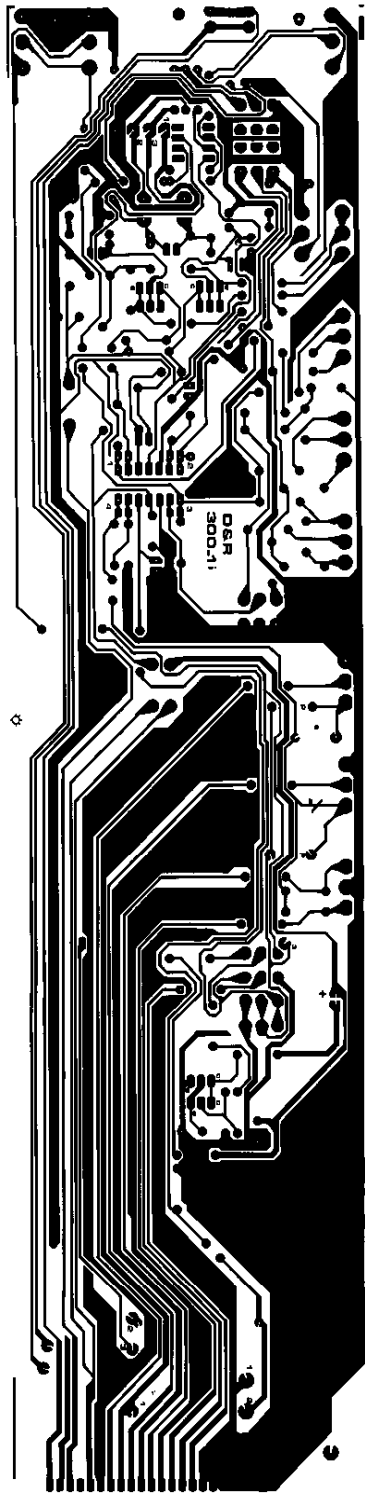

| | | | | | | | |
|------------------------|--|---------------|--|-------------------------------------|--|-------|--|
| TELEX: 18503 dr nl | | TITLE : | | THIS DRAWING REPLACES PREVIOUS ONES | | NOTES | |
| TELEPHONE: 02940-18014 | | 300 1i | | INDEX | | | |
| RIJNKADE 15b | | mono chan | | MOD. BY. | | | |
| 13826S WEESP | | PCB. REF. nr: | | DATE | | | |
| Electronica by Holland | | DESIGN : | | CHECK 1 | | | |
| | | DATE : | | CHECK 2 | | | |
| | | SHEET | | DRAWN | | | |
| | | OF | | | | | |

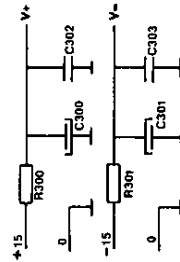
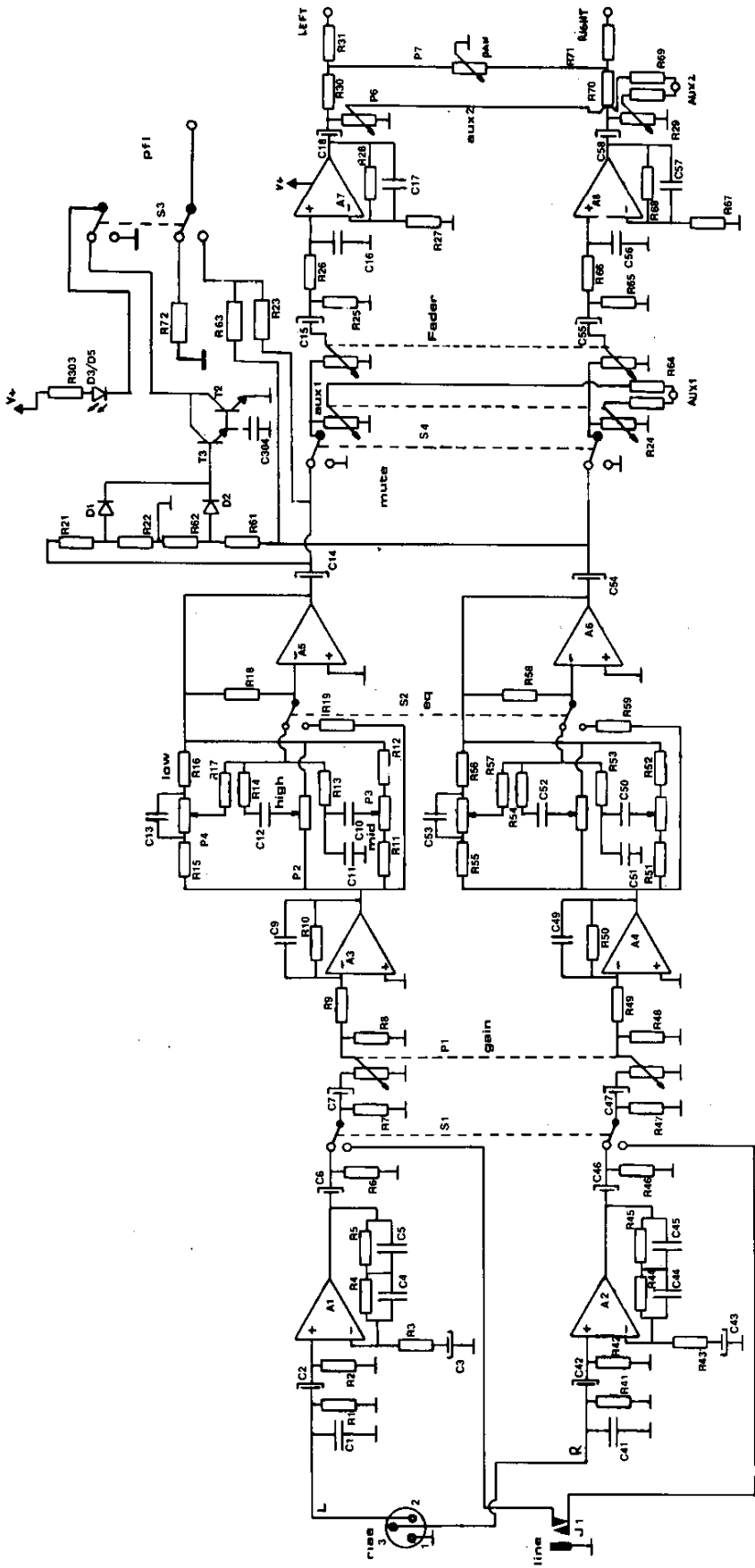

TELEX: 18503 dr N
 TELEPHONE: 02940-18014
 RIJNSKADE 15B
 1382 GS WEESP
 Electronics by Holland

TITLE :
**SERIES 300
 STEREO CHAN.**

PCB. REF. no.:
 DESIGN :
 DATE :

THIS DRAWING REPLACES PREVIOUS ONES

| INDEX | MOD. BY. | DATE | CHECK 1 | CHECK 2 | DRAWN |
|-------|----------|------|---------|---------|-------|
| | | | | | |
| | | | | | |
| | | | | | |
| | | | | | |
| | | | | | |

NOTES

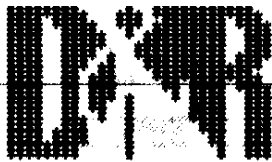

Rijnkade 15b
1302 GS WESP
TLX. 18503 dr nl
TEL. 02940-18814

Date : 13-08-1987

Electronica b.v. HOLLAND

R & D department

PARTLIST : 300-2 STEREO CHANNEL mark 2

printindex: h

| | PartNr | Value | Notes | ArtNr | |
|--|----------|-------------------------|---------|-------|------|
| | RIAA | R1/R41 | 100 k | 5% | 0753 |
| | | R2/R42 | 100 k | 5% | 0753 |
| | | R3/R43 | 390 E | 5% | 0742 |
| | | R4/R44 | 100 k | 5% | 0753 |
| | | R5/R45 | 10 k | 5% | 0741 |
| | | R6/R46 | 47 k | 5% | 0749 |
| | line | R7/R47 | 100 k | 5% | 0753 |
| | | R8/R48 | 6 k 8 | 5% | 0739 |
| | | R9/R49 | 22 k | 5% | 0745 |
| | | R10/R50 | 220 k | 5% | 0757 |
| | eq. | R11/R51 | 10 k | 5% | 0741 |
| | | R12/R52 | 10 k | 5% | 0741 |
| | | R13/R53 | 10 k | 5% | 0741 |
| | | R14/R54 | 18 k | 5% | 0744 |
| | | R15/R55 | 10 k | 5% | 0741 |
| | | R16/R56 | 10 k | 5% | 0741 |
| | | R17/R57 | 47 k | 5% | 0749 |
| | | R18/R58 | 1 M | 5% | 0765 |
| | | R19/R59 | 1 M | 5% | 0765 |
| | leddr | R20/R60 (not in mk2) | 22 k | 5% | 0745 |
| | | R21/R61 | 47 k | 5% | 0749 |
| | | R22/R62 | 22 k | 5% | 0745 |
| | pfl | R23/R63 | 18 k | 5% | 0744 |
| | aux 1 | R24/R64 | 100 k | 5% | 0753 |
| | fader | R25/R65 | 100 k | 5% | 0753 |
| | | R26/R66 | 1 k 0 | 5% | 0729 |
| | | R27/R67 (not in mk2) | 1 k 0 | 5% | 0729 |
| | | R27/R67 (only in mk2) | 10 k | 5% | 0741 |
| | | R28/R68 (not in mk2) | 1 k 0 | 5% | 0729 |
| | | R28/R68 (only in mk2) | 22 k | 5% | 0745 |
| | aux 2 | R29/R69 | 18 k | 5% | 0744 |
| | pan | R30/R70 | 6 k 8 | 5% | 0739 |
| | L,R buss | R31/R71 | 39 k | 5% | 0748 |
| | | R72 | 10 k | 5% | 0741 |
| | | R300 | 10 E | 5% | 0705 |
| | | R301 | 10 E | 5% | 0705 |
| | | R302 (not in mk2) | 1 k 0 | 5% | 0729 |
| | | R303 | 1 k 0 | 5% | 0729 |
| | RIAA | C1/C41 | 270 p | ker | 0230 |
| | | C2/C42 | 47 / 25 | elco | 0287 |
| | | C3/C43 | 47 / 25 | elco | 0287 |
| | | C4/C44 | 0.033 | pol | 0257 |
| | | C5/C45 | 6800 p | pol | 0251 |
| | line | C7/C47 | 47 / 25 | elco | 0287 |
| | | C9/C49 | 2 p 2 | ker | 0205 |
| | eq. | C10/C50 | 6800 p | pol | 0251 |
| | | C11/C51 | 0.01 | pol | 0253 |
| | | C12/C52 | 1000 p | pol | 0236 |
| | | C13/C53 | 0.022 | pol | 0246 |
| | | C14/C54 | 47 / 25 | elco | 0287 |
| | | C15/C55 | 47 / 25 | elco | 0287 |

| | | | | |
|----------|--------------------|------------------|--------------------|-----------|
| fader | C16/C56 | 270 p | ker | 0230 |
| | C17/C57 | 22 p | ker | 0217 |
| | C18/C58 | 47 / 25 | elco | 0287 |
| | C300 | 47 / 25 | elco | 0287 |
| | C301 | 47 / 25 | elco | 0287 |
| | C302 | 0.1 / 63 | ker | 0241 |
| | C303 | 0.1 / 63 | ker | 0241 |
| | C304 | 47 / 25 | elco | 0287 |
| leddr | T1 (not in mk2) | BC 546 | NPN | 0328 |
| | T2 | BC 546 | NPN | 0328 |
| | T3 | BC 546 | NPN | 0328 |
| RIAA | A1-A2 | NE 5532 | lown | 0307 |
| line-eq. | A3-A6 | TL 074 | bifET | 0305 |
| fader | A7-A8 | TL 072 | bifET | 0304 |
| leddr | D1 | 1N4148 | sgn | 0342 |
| | D2 | 1N4148 | sgn | 0342 |
| leddr | D3 (not in mk2) | led 3mm | red | 0387 |
| | D4 (not in mk2) | led 3mm | green | 0386 |
| | D5 (only in mk2) | led 5 x 2 mm | red | 0390 |
| | P1 | 100 kA st | 15mm | 0114 |
| | P2 | 100 kA st | 15mm | 0114 |
| | P3 | 100 kA st | 15mm | 0114 |
| | P4 | 100 kA st | 15mm | 0114 |
| | P5 | 22 kB st | 15mm | 0109 |
| | P6 | 22 kB st | 15mm | 0109 |
| | P7 | 10 kA | 15mm (12) | 0108 |
| fader | F1 (not in mk2) | 10 kB RADIOHM | 58mm stereo fader | 0132 |
| | F2 (only in mk2) | 10 kB ALPS norm. | 100mm stereo fader | 0571 |
| | S1 | 2 x 2 | FOX N2UEE | 0400 |
| | S2 | 2 x 2 | FOX N2UEE | 0400 |
| | S3 | 2 x 2 | FOX N2UEE | 0400 |
| | S4 | 2 x 2 | FOX N2UEE | 0400 |
| remote | S5 | startswitch | (optional) | 0407/0410 |
| RIAA | J1 | XLR 3 pin | fem.plastic | 0424 |
| line | J2 | jack stereo | CLIFF plastic | 0433 |
| remote | J3 | jack mono | 3.5mm (optional) | ---- |
| CONN1 | | 0.1" 17 pins | MOLEX 4030 | 0980 |

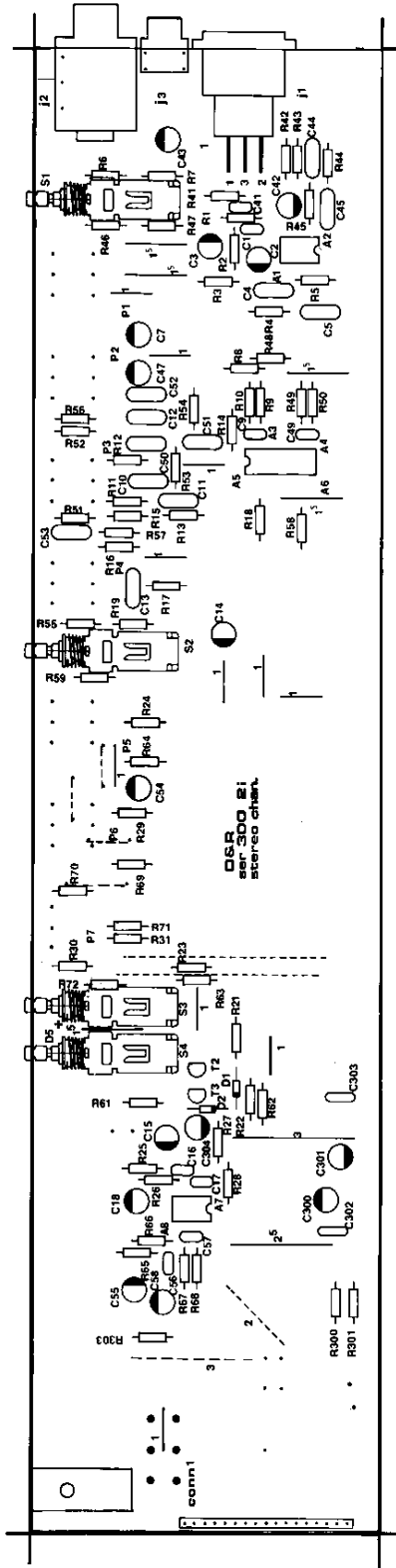
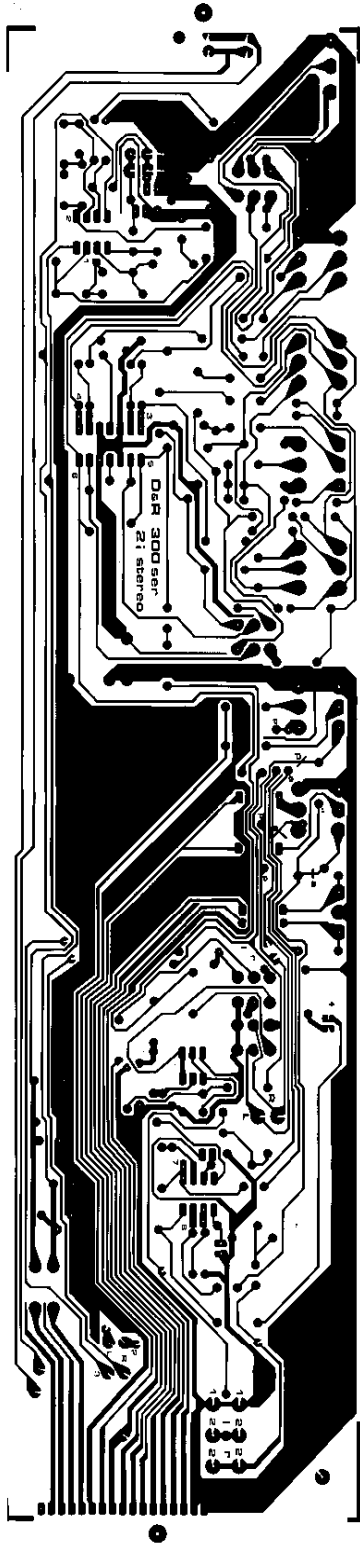

TELEX: 18503 dr nl
 TELEPHONE: 02940-18014
 RIJNSKADE 15b
 1382GS WEESP

TITLE :
300 2i
 stereo chan

PCB. REF. NR.
 DESIGN :
 DATE :
 SHEET : OF

THIS DRAWING REPLACES PREVIOUS ONES

| INDEX | MOD. BY. | DATE | CHECK 1 | CHECK 2 | DRAWN |
|-------|----------|------|---------|---------|-------|
| | | | | | |
| | | | | | |
| | | | | | |
| | | | | | |
| | | | | | |
| | | | | | |

NOTES :

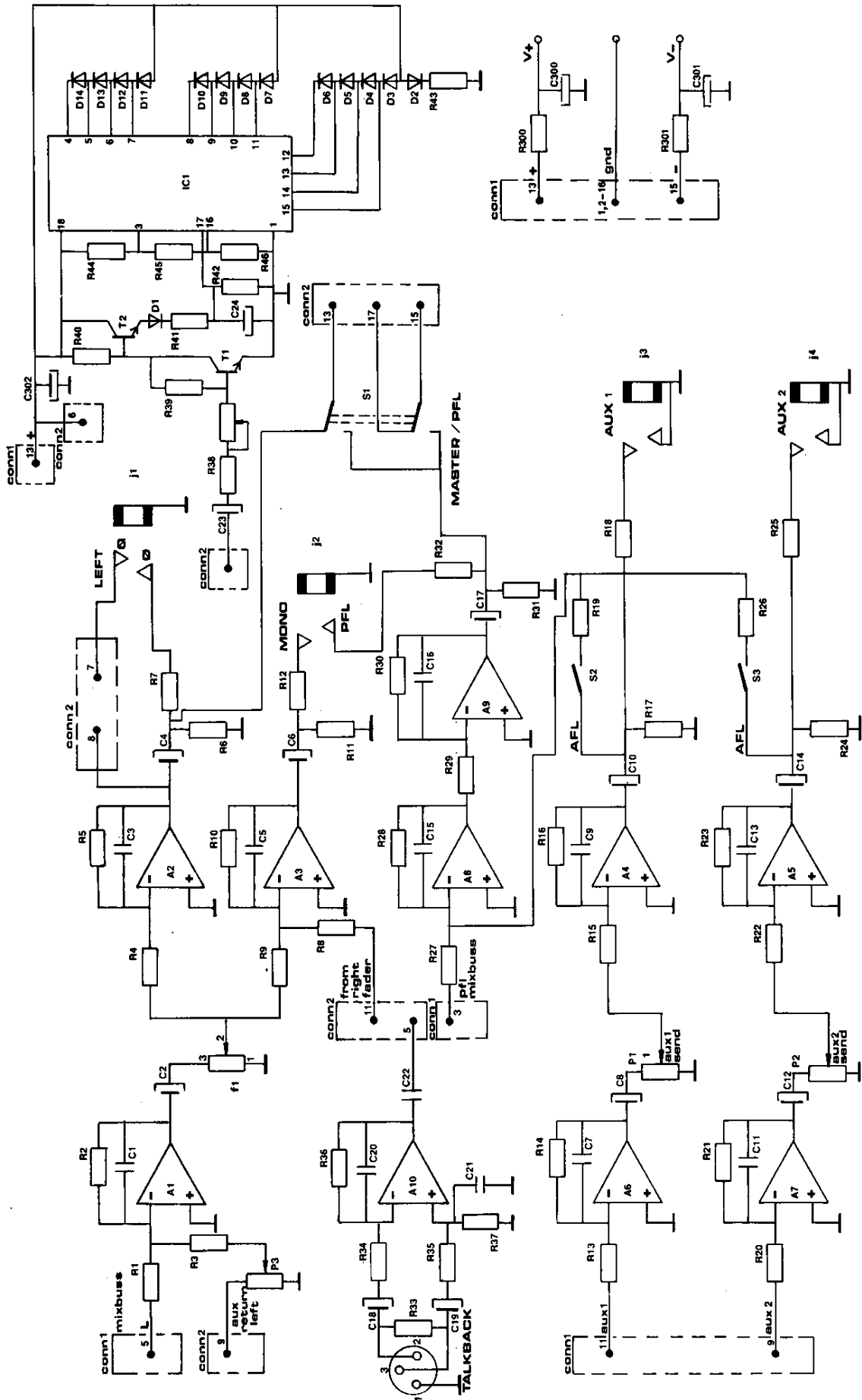

NOTES

THIS DRAWING REPLACES PREVIOUS ONES

| INDEX | MOD. BY. | DATE | CHECK 1 | CHECK 2 | DRAWN |
|-------|----------|------|---------|---------|-------|
| | | | | | |
| | | | | | |
| | | | | | |
| | | | | | |

TITLE : **SER. 300-3**

LEFT MASTER

TELEX : 18503 dr nl
 TELEPHONE : 02940-18014
 DESIGN : RIJNSKADE 15b
 DATE : 1982GS WEESP

DAB
 Electronics by Holland

OF

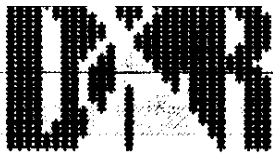

Rijnkade 15b
1302 GS NEESS
TLX. 18583 dr nl
TEL. 02940-18814

Date : !!/"//####

R & D department

PARTLIST : 300-3

LEFT MASTER mark 2

PCB-index : d

| PartNr | Value | Notes | ArtNr |
|--------|---------|-------|-------|
| R1 | 33 E | 5% | 0711 |
| R2 | 100 k | 5% | 0753 |
| R3 | 10 k | 5% | 0741 |
| R4 | 10 k | 5% | 0741 |
| R5 | 10 k | 5% | 0741 |
| R6 | 47 k | 5% | 0749 |
| R7 | 100 E | 5% | 0717 |
| R8 | 20 k | 1% | 0856 |
| R9 | 20 k | 1% | 0856 |
| R10 | 10 k | 5% | 0741 |
| R11 | 47 k | 5% | 0749 |
| R12 | 100 E | 5% | 0717 |
| R13 | 33 E | 5% | 0711 |
| R14 | 100 k | 5% | 0753 |
| R15 | 10 k | 5% | 0741 |
| R16 | 10 k | 5% | 0741 |
| R17 | 47 k | 5% | 0749 |
| R18 | 100 E | 5% | 0717 |
| R19 | 10 k | 5% | 0741 |
| R20 | 33 E | 5% | 0711 |
| R21 | 22 k | 5% | 0745 |
| R22 | 10 k | 5% | 0741 |
| R23 | 10 k | 5% | 0741 |
| R24 | 47 k | 5% | 0749 |
| R25 | 100 E | 5% | 0717 |
| R26 | 10 k | 5% | 0741 |
| R27 | 33 E | 5% | 0711 |
| R28 | 10 k | 5% | 0741 |
| R29 | 10 k | 5% | 0741 |
| R30 | 10 k | 5% | 0741 |
| R31 | 47 k | 5% | 0749 |
| R32 | 100 E | 5% | 0717 |
| R33 | 10 k | 5% | 0741 |
| R34 | 560 E | 5% | 0726 |
| R35 | 560 E | 5% | 0726 |
| R36 | 56 k | 5% | 0750 |
| R37 | 56 k | 5% | 0750 |
| R38 | 1 k 0 | 5% | 0729 |
| R39 | 47 k | 5% | 0749 |
| R40 | 10 k | 5% | 0741 |
| R41 | 180 E | 5% | 0720 |
| R42 | 150 k | 5% | 0755 |
| R43 | 1 k 0 | 5% | 0729 |
| R44 | 15 k | 5% | 0743 |
| R45 | 10 k | 5% | 0741 |
| R46 | 270 E | 5% | 0722 |
| R300 | 10 E | 5% | 0705 |
| R301 | 10 E | 5% | 0705 |
| C1 | 4 p 7 | ker | 0209 |
| C2 | 47 / 25 | elco | 0287 |
| C3 | 4 p 7 | ker | 0209 |
| C4 | 47 / 25 | elco | 0287 |
| C5 | 4 p 7 | ker | 0209 |

| | | | |
|---------|------------------|---------------|------|
| C6 | 47 / 25 | elco | 0287 |
| C7 | 4 p 7 | ker | 0209 |
| C8 | 47 / 25 | elco | 0287 |
| C9 | 4 p 7 | ker | 0209 |
| C10 | 47 / 25 | elco | 0287 |
| C11 | 4 p 7 | ker | 0209 |
| C12 | 47 / 25 | elco | 0287 |
| C13 | 4 p 7 | ker | 0209 |
| C14 | 47 / 25 | elco | 0287 |
| C15 | 22 p | ker | 0217 |
| C16 | 4 p 7 | ker | 0209 |
| C17 | 47 / 25 | elco | 0287 |
| C18 | 47 / 25 | elco | 0287 |
| C19 | 47 / 25 | elco | 0287 |
| C20 | 10 p | ker | 0213 |
| C21 | 10 p | ker | 0213 |
| C22 | 0.1 u | poly | 0261 |
| C23 | 47 / 25 | elco | 0287 |
| C24 | 4.7 / 63 | elco | 0281 |
| C300 | 47 / 25 | elco | 0287 |
| C301 | 47 / 25 | elco | 0287 |
| C302 | 47 / 25 | elco | 0287 |
| A1 | NE 5534 | lowns | 0306 |
| A2-A5 | TL 074 | bifET | 0305 |
| A6-A9 | TL 074 | bifET | 0305 |
| A10 | TL 071 | bifET | 0303 |
| IC1 | UA 180 | LED 12 | 0308 |
| T1 | BC 337 | NPN | 0332 |
| T2 | BC 337 | NPN | 0332 |
| D1 | 1N4148 | SGN | 0342 |
| D2-D11 | 5 x 2 | LED green | 0389 |
| D12-D14 | 5 x 2 | LED red | 0390 |
| S1 | 2 x 2 | FOX | 0400 |
| S2 | 2 x 2 | FOX | 0400 |
| S3 | 2 x 2 | FOX | 0400 |
| J1 | jack stereo | CLIFF plastic | 0433 |
| J2 | jack stereo | CLIFF plastic | 0433 |
| J3 | jack stereo | CLIFF plastic | 0433 |
| J4 | jack stereo | CLIFF plastic | 0433 |
| J5 | XLR 3 pin | fem. plastic | 0427 |
| F1 | 10 kB mono fader | NOBLE 100mm | 0138 |
| CONN1 | 0.1" 17 pins | MOLEX 4030 | 0980 |
| CONN2 | 0.1" 17 pins | MOLEX 4030 | 0980 |
| P1 | 10 kB | 15mm mono | 0104 |
| P2 | 10 kB | 15mm mono | 0104 |
| P3 | 10 kB | 15mm mono | 0104 |
| VR1 | 47 k | mini trimmer | 0147 |

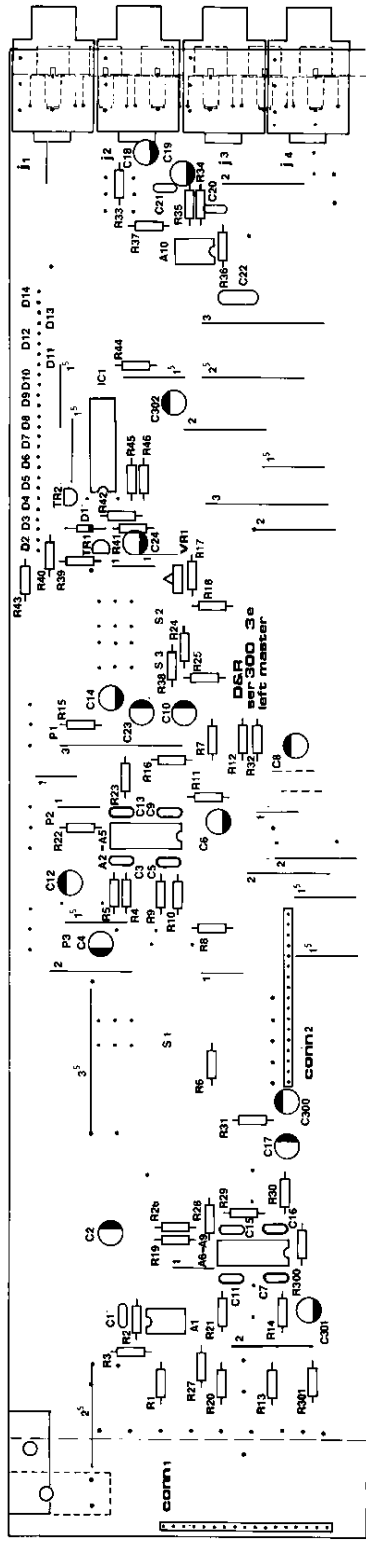
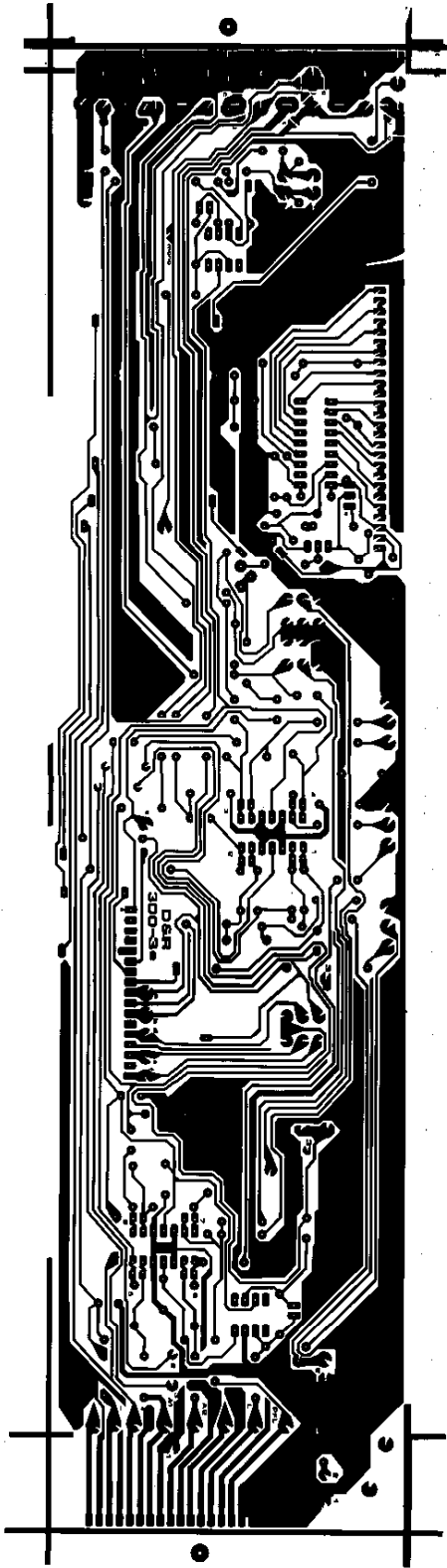

TELEX: 18503 dr nl
 TELEPHONE: 02940-18044
 RIJNKADE 15b
 1382GS WEESP
 Electronic bv Holland

TITLE : **300-3e**

THIS DRAWING REPLACES PREVIOUS ONES

| | |
|----------|--|
| INDEX | |
| MOD. BY. | |
| DATE | |
| CHECK 1 | |
| CHECK 2 | |
| DRAWN | |

NOTES :

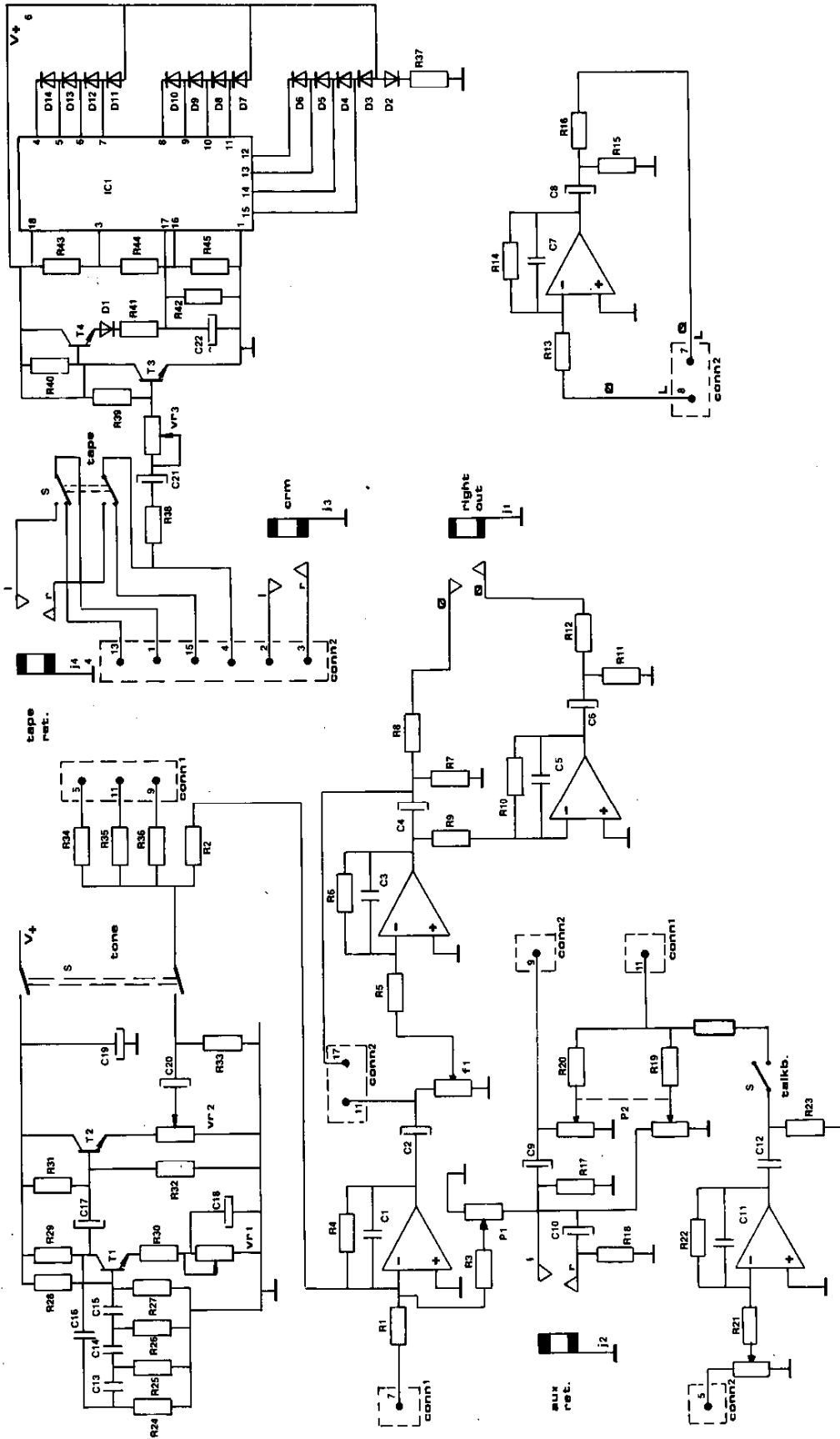

NOTES

THIS DRAWING REPLACES PREVIOUS ONES

| | |
|----------|--|
| INDEX | |
| MOD. BY. | |
| DATE | |
| CHECK 1 | |
| CHECK 2 | |
| DRAWN | |

TITLE : 300-4

TELEX : 18503 dr n
 TELEPHONE : 02940-1804
 DESIGN : RIJNSKADE 15D
 DATE : 1982GS HESP
 SHEET : OF

DA
 Electronica by Holland

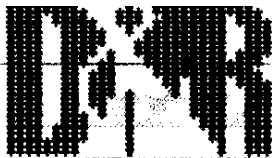

Rijkade 15b
 1382 GS MEESP
 TLX. 18583 dr nl
 TEL. 02940-18814

Date : // / //

Electronica b.v. HOLLAND

R & D department

PARTLIST : 300-4

RIGHT MASTER mark 2

PCB-index : d

| PartNr | Value | Notes | PartNr |
|--------|---------|-------|--------|
| R1 | 33 E | 5% | 0711 |
| R2 | 100 k | 5% | 0741 |
| R3 | 10 k | 5% | 0741 |
| R4 | 100 k | 5% | 0753 |
| R5 | 10 k | 5% | 0741 |
| R6 | 10 k | 5% | 0741 |
| R7 | 47 k | 5% | 0744 |
| R8 | 100 E | 5% | 0717 |
| R9 | 10 k | 5% | 0741 |
| R10 | 10 k | 5% | 0741 |
| R11 | 47 k | 5% | 0744 |
| R12 | 100 E | 5% | 0717 |
| R13 | 10 k | 5% | 0741 |
| R14 | 10 k | 5% | 0741 |
| R15 | 47 k | 5% | 0744 |
| R16 | 100 E | 5% | 0717 |
| R17 | 47 k | 5% | 0744 |
| R18 | 47 k | 5% | 0744 |
| R19 | 10 k | 5% | 0741 |
| R20 | 10 k | 5% | 0741 |
| R21 | 10 k | 5% | 0741 |
| R22 | 680 k | 5% | 0763 |
| R23 | 47 k | 5% | 0744 |
| R24 | 12 k 1 | 1% | 0851 |
| R25 | 12 k 1 | 1% | 0851 |
| R26 | 12 k 1 | 1% | 0851 |
| R27 | 12 k 1 | 1% | 0851 |
| R28 | 56 k | 5% | 0750 |
| R29 | 4 k 7 | 5% | 0737 |
| R30 | 100 E | 5% | 0717 |
| R31 | 100 k | 5% | 0753 |
| R32 | 100 k | 5% | 0753 |
| R33 | 12 k | 5% | 0742 |
| R34 | 100 k | 5% | 0753 |
| R35 | 100 k | 5% | 0753 |
| R36 | 10 k | 5% | 0744 |
| R37 | 1 k | 5% | 0729 |
| R38 | 1 k | 5% | 0729 |
| R39 | 47 k | 5% | 0744 |
| R40 | 10 k | 5% | 0741 |
| R41 | 180 E | 5% | 0720 |
| R42 | 150 k | 5% | 0755 |
| R43 | 15 k | 5% | 0743 |
| R44 | 10 k | 5% | 0741 |
| R45 | 270 E | 5% | 0722 |
| R46 | 47 k | 5% | 0744 |
| R300 | 10 E | 5% | 0705 |
| R301 | 10 E | 5% | 0705 |
| C1 | 4 p 7 | ker | 0209 |
| C2 | 47 / 25 | elco | 0287 |
| C3 | 4 p 7 | ker | 0209 |
| C4 | 47 / 25 | elco | 0287 |
| C5 | 4 p 7 | ker | 0209 |

→ 47k.
 → 10k

| | | | |
|---------|------------------|---------------|------|
| C6 | 47 / 25 | elco | 0287 |
| C7 | 4 p 7 | ker | 0209 |
| C8 | 47 / 25 | elco | 0287 |
| C9 | 47 / 25 | elco | 0287 |
| C10 | 47 / 25 | elco | 0287 |
| C11 | 2 p 2 | ker | 0205 |
| C12 | 0.1 | poly | 0261 |
| C13 | 0.01 | poly | 0253 |
| C14 | 0.01 | poly | 0253 |
| C15 | 0.01 | poly | 0253 |
| C16 | 0.01 | poly | 0253 |
| C17 | 4.7 / 63 | elco | 0281 |
| C18 | 47 / 25 | elco | 0287 |
| C19 | 100 / 25 | elco | 0292 |
| C20 | 47 / 25 | elco | 0287 |
| C21 | 47 / 25 | elco | 0287 |
| C22 | 4.7 / 63 | elco | 0281 |
| C300 | 47 / 25 | elco | 0281 |
| C301 | 47 / 25 | elco | 0287 |
| | | | |
| A1 | NE5534 | lowns | 0306 |
| A2-A5 | TL074 | biFET | 0305 |
| | | | |
| IC1 | UAA 180 | led 12 | 0308 |
| | | | |
| T1 | BC 546 B | NPN | 0328 |
| T2 | BC 546 B | NPN | 0328 |
| T3 | BC 337 | NPN | 0332 |
| T4 | BC 337 | NPN | 0332 |
| | | | |
| D1 | 1N4148 | sgn | 0342 |
| D2-D11 | LED 5 x 2 mm | green | 0389 |
| D12-D14 | LED 5 x 2 mm | red | 0390 |
| | | | |
| P1 | 10 kB | 15mm mono | 0104 |
| P2 | 22 kB | 15mm stereo | 0109 |
| P3 | 10 kB | 15mm mono | 0104 |
| | | | |
| CONN1 | 4030 0.1'' | MOLEX | 0980 |
| CONN2 | 4030 0.1'' | MOLEX | 0980 |
| | | | |
| S1 | N2 UEE 2 x 2 | FOX | 0400 |
| S2 | N2 UEE 2 x 2 | FOX | 0400 |
| S3 | N2 UEE 2 x 2 | FOX | 0400 |
| | | | |
| J1 | jack stereo | CLIFF plastic | 0433 |
| J2 | jack stereo | CLIFF plastic | 0433 |
| J3 | jack stereo | CLIFF plastic | 0433 |
| J4 | jack stereo | CLIFF plastic | 0433 |
| | | | |
| F1 | 10 kB mono fader | NOBLE 100mm | 0132 |
| | | | |
| VR1 | 4 k 7 | mini trimmer | 0144 |
| VR2 | 4 k 7 | mini trimmer | 0144 |
| VR3 | 47 k | mini trimmer | 0147 |

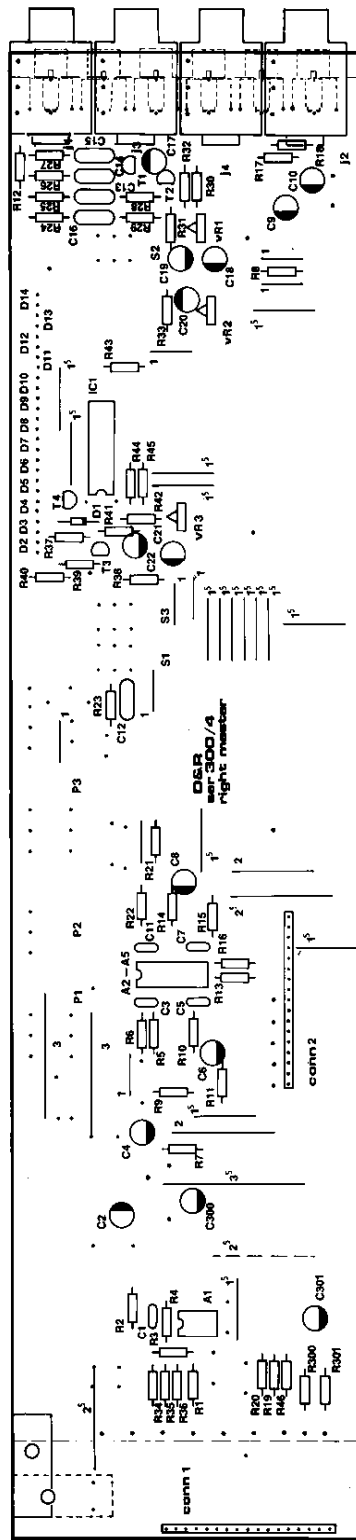
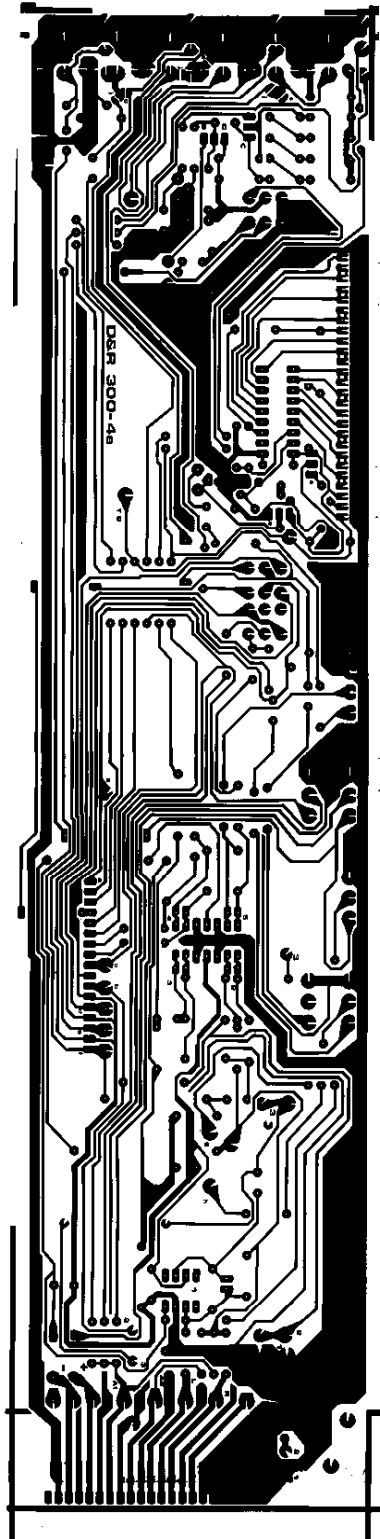

DB
 Electronica by Holland

TELEX: 18503 dr nl
 TELEPHONE: 02940-18014
 RIJNSKADE 15b
 1382GS WEESEP

TITLE : **300/4**
 right master
 PCB.REF.nr.:
 DESIGN:
 DATE :
 SHEET _____ OF _____

THIS DRAWING REPLACES PREVIOUS ONES

| INDEX | MOD. BY. | DATE | CHECK 1 | CHECK 2 | DRAWN |
|-------|----------|------|---------|---------|-------|
| | | | | | |
| | | | | | |
| | | | | | |
| | | | | | |
| | | | | | |

NOTES :

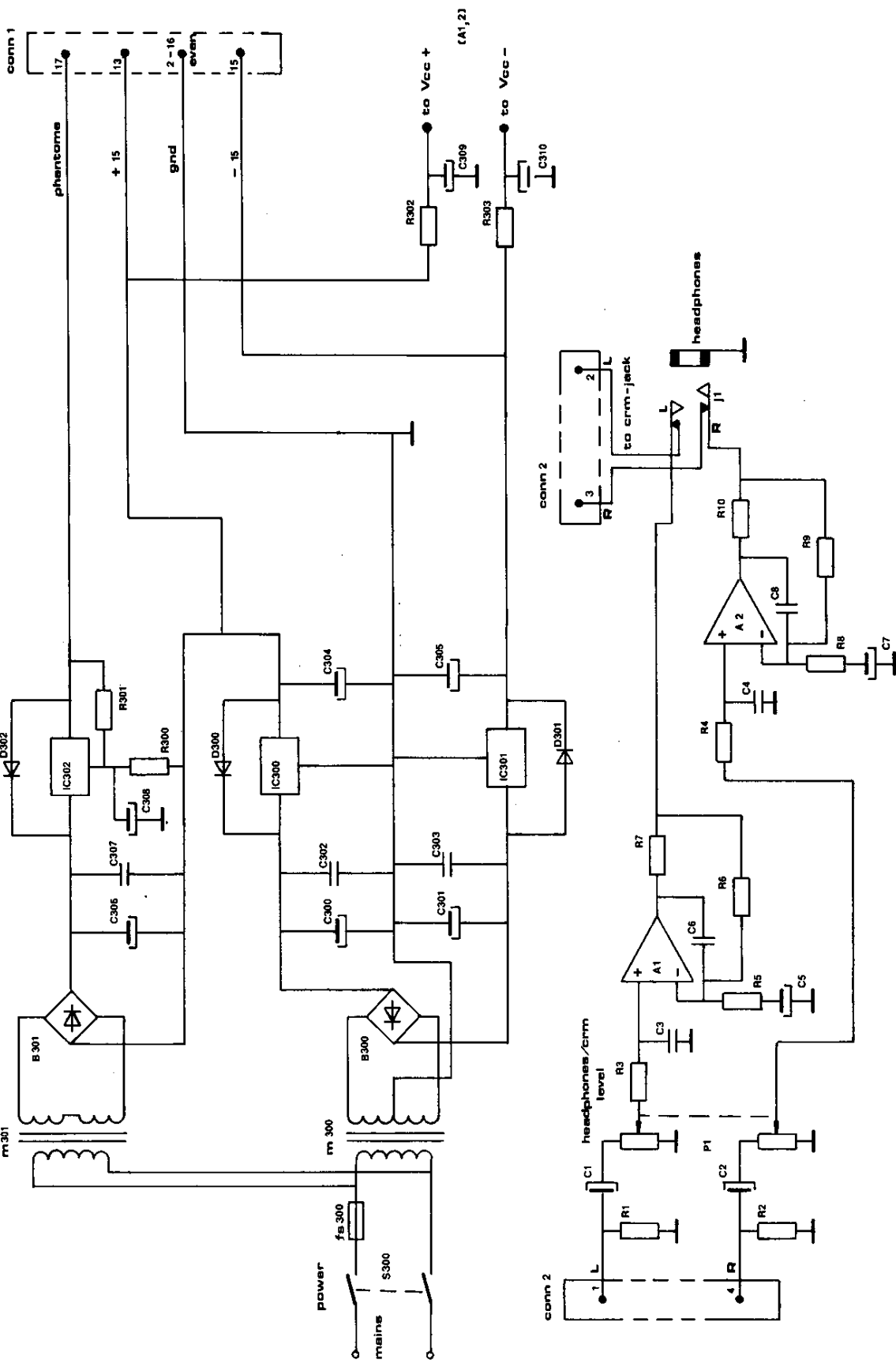

THIS DRAWING REPLACES PREVIOUS ONES

| INDEX | MOD. BY. | DATE | CHECK 1 | CHECK 2 | DRAWN |
|-------|----------|------|---------|---------|-------|
| | | | | | |
| | | | | | |
| | | | | | |
| | | | | | |

TITLE :

300-5

PCB REF. nr. :

DESIGN :

DATE :

SHEET OF

TELEX: 18503 dr nl
 TELEPHONE: 02940-18014
 RIJNSKADE 15b
 13826S WEESP
 Electronica by Holland

NOTES

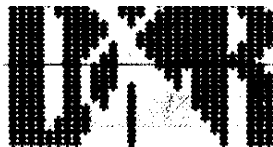

Rijnkade 15b
1382 GS NEESP
TLX. 18583 dr nl
TEL. 02940-18814

Electronica b.v. HOLLAND

Date : !!/"//####

R & D department

PARTLIST : 300-5

POWER SUPPLY mark 2

PCB-index : c

| PartNr | Value | Notes | ArtNr |
|--------|-----------------------|---------------|-------|
| R1 | 47 k | 5% | 0749 |
| R2 | 47 k | 5% | 0749 |
| R3 | 1 k | 5% | 0729 |
| R4 | 1 k | 5% | 0729 |
| R5 | 1 k | 5% | 0729 |
| R6 | 8 k 2 | 5% | 0740 |
| R7 | 47 E | 5% | 0713 |
| R8 | 1 k | 5% | 0729 |
| R9 | 8 k 2 | 5% | 0740 |
| R10 | 47 E | 5% | 0713 |
| R300 | 820 E | 5% | 0728 |
| R301 | 3 k 9 | 5% | 0736 |
| R302 | 10 E | 5% | 0705 |
| R303 | 10 E | 5% | 0705 |
| C1 | 47 / 25 | elco | 0287 |
| C2 | 47 / 25 | elco | 0287 |
| C3 | 270 p | ker | 0230 |
| C4 | 270 p | ker | 0230 |
| C5 | 47 / 25 | elco | 0287 |
| C6 | 4 p 7 | ker | 0209 |
| C7 | 47 / 25 | elco | 0287 |
| C8 | 4 p 7 | ker | 0209 |
| C300 | 4700 / 25 | elco | 0258 |
| C301 | 4700 / 25 | elco | 0298 |
| C302 | 0.1 / 63 | ker | 0241 |
| C303 | 0.1 / 63 | ker | 0241 |
| C304 | 100 / 25 | elco | 0292 |
| C305 | 100 / 25 | elco | 0292 |
| C306 | 2200 / 63 | elco | 0272 |
| C307 | 0.1 / 63 | ker | 0241 |
| C308 | 220 / 63 | elco | 0293 |
| C309 | 47 / 25 | elco | 0287 |
| C310 | 47 / 25 | elco | 0287 |
| D300 | 1N4003 | rct | 0343 |
| D301 | 1N4003 | rct | 0343 |
| D302 | 1N4003 | rct | 0343 |
| B300 | BC80C1000 | bridge rect. | 0345 |
| B301 | BC80C1000 | bridge rect. | 0345 |
| A1-A2 | TL072 | biFET | 0304 |
| IC300 | 7815 T0220 | pos.reg | 0320 |
| IC301 | 7915 T0220 | neg.reg | 0321 |
| IC302 | 7824 T0220 | pos.reg | 0324 |
| M300 | 2 x 15 v 15VA(torrod) | ILP 06013 | 0586 |
| M301 | 2 x 15 v | AMROH P343 | 0593 |
| S300 | 2 x 2 NE15 | SHADOW print | 0406 |
| FS300 | 500 mA slow | fuse + holder | 0675 |

| | | | |
|-------|------------|--------------|--------------|
| J1 | jack break | CLIFF plast. | 0703 0432 |
| P1 | 22 kB | stereo | 0109 |
| CONN1 | 4030 0.1'' | MOLEX | 0980 |
| CONN2 | 4030 0.1'' | MOLEX | 0980 |

Specifications:

Inputs : Mic inputs balanced 2 kOhm by way of female XLR
CMMR at 50 Hz - 70 dB.
Line input: balanced 10 kOhm
Insert: 0 dBu level 100 Ohm/10 kOhm impedance by way of stereo breakjack.
Min/max mic input sensitivity: -70 dBu to -30 dBu for 0 dBu out.
Min/max line input sensitivity: -20 dBu to infinity.
Aux returns: -20 dBu at 10 kOhm
Tape returns: 0 dBu at 10 kOhm.

Outputs : Left/right/mono/Aux 1/2 o dBu at 100 Ohm. (only left/right is balanced)

Options : Stereo R.I.A.A. channels
Fader start switches

Noise : Mic input at max gain: -126,5 dBu
20 - 20.000 Hz.
Output noise master faders down: -92 dBu.
Output noise master faders up: -80 dBu.

Freq. response : 20 - 20.000 Hz $\pm 0,025$ dB at 80.000 Hz -3 dB

Equalization : ± 18 dB at 15.000 Hz shelve (± 16 dB at 10 kHz)
 ± 12 dB at 1.000 Hz bell
 ± 18 dB at 50 Hz shelve (± 16 dB at 70 Hz)

Overall : Total harmonic distortion less than 0,039%.
Max gain through desk 80 dB incl. postfader gain of 10 dB.

Dimensions : 483 x 85 mm x 400 mm

D&R SERIES 300 MARK II

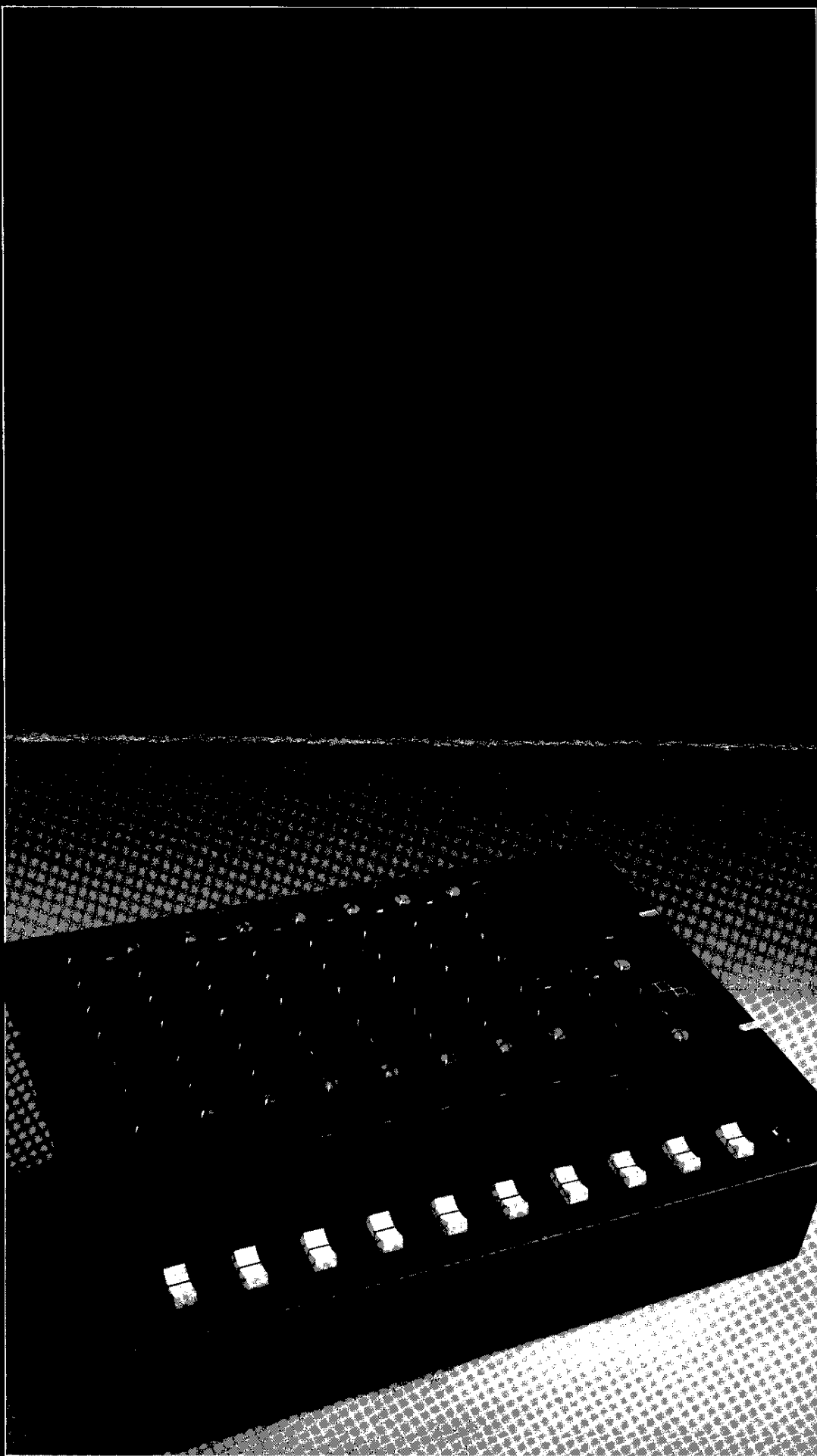

D&R SERIES 300 MARK II

GENERAL INFORMATION

The 300 series are the latest development in mixing-desk design from D&R. It was designed to supply the increased demand for a 19 inch rack mounting desk. The 300 series has basically 8 mono inputs with balanced mic inputs. Stereo channels are available as an optional extra with R.I.A.A. correction and stereo line inputs.

Our long experience, we have been more than 14 years in the business, is your guarantee that you buy a mixing desk with very high specifications. We know how to maintain the superb performance of the now-days integrated circuits. They can be easily ruined by bad printed circuitboard lay-outs with subsequent over-compensation, resulting in transient distortion. Our electronics are absolutely stable and our desks would have a linear frequency response of more than 500 kHz if they were not passively compensated. Because of the excellent printed circuitboard lay-out and design, crosstalk and distortion are so low that they are insignificant.

Active compensation is employed around integrated circuits only to cope with ringing and overshoot. This is the only way to assure you of a superb transparency in your recordings. The bandwidth in our consoles is limited only through passive filtering. If the configuration of even one integrated circuit in your console is not properly designed it will degrade the sound. This extremely important aspect will not show up in the specifications. If an integrated circuit has a slew rate of 13 Volt per usec does not necessarily say that your console has it. Proper transient handling is one of the most important things in a desk. Our desks can handle any transient.

Other features

The 300 series is especially designed for high-quality stereo recording in Audio & Video productions and can also be used in a discotheque as well as stereo broadcasting.

The input channel features are:

An electronically balanced XLR microphone input and a separate balanced line input for line-level signals. A dual gain control with a smooth range adjusts both the mic and line signals. Switchable phantom powering of 48 Volt is standard. The ideal combination of integrated circuits and discrete transistors assures you of a very low noise level of -126.5 dBu in your mic amps. The equalizer is of our well proven design with on/off switching. Of the two Aux sends 1 is prefader wired and Aux 2 postfader wired. Internal links can change this. The Panpot pans the signal between the outputs. The peak led turns on when the signal reaches +18 dBu, this is 4 dB below clipping. A high quality carbon track fader completes the channel. Another important feature of the channels are the insertion points to connect ancillary equipment to the desk. In the case of stereo channels, insertion points are not provided. The pfl button in conjunction with the master pfl/afll switch gives you pre-fader listening in the channels together with visual indication of the present level on the led bargraphs.

Master section

The master section consists of 4 main outputs, the left / right outputs and the Aux 1 / 2 outputs. Furthermore there is a talkback circuit which gives its signal into the Aux 1 master. There is a stereo Aux 2 return which has separate left & right controls for mixing into the left / right master busses and a single control for mixing into the Aux 1 buss. The monitoring section with associated controls such as master pfl/afll switch and Aux 1 / 2 afll switches has also a stereo tape return switch.

The outputs are all on jack sockets. Besides the left & right outputs there is a mono output. 13 Segments led-bargraphs provide excellent metering.

Cosmetics

The desk itself is made out of grey aluminium with unerasable lettering. It has an all metal housing which gives excellent screening against R-F interference. The desk can be housed in a 19" rack if desired and occupies the space of 9 E. units of 44.45 mm.

We are sure if you decide to purchase this console you will never be disappointed. You get a one year warranty on all parts and labour. In the rare event that something should occur despite double testing and 24-hours burn-in we will help you within 24 hours, sometimes you can wait for a repair.

Options

Stereo R.I.A.A. channels.
Conductive plastic faders.
A.L.P.S. luxe faders.

Specifications:

| | |
|----------------|---|
| Inputs | : Mic inputs balanced 2 kOhm by way of female XLR CMRR at 50 Hz - 70 dB Line input: balanced 10 kOhm Insert: 0 dBu level 100 Ohm/10 kOhm impedance by way of stereo breakjack. Min/max mic input sensitivity: -70 dBu to -30 dBu for 0 dBu out. Min/max line input sensitivity: -20 dBu to infinity. Aux returns: -20 dBu at 10 kOhm Tape returns: 0 dBu at 10 kOhm. |
| Outputs | : Left/right/mono/Aux 1/2 o dBu at 100 Ohm. (only left/right is balanced) |
| Options | : Stereo R.I.A.A. channels Fader start switches |
| Noise | : Mic input at max gain: -126,5 dBu 20 - 20.000 Hz. Output noise master faders down: -92 dBu. Output noise master faders up: -80 dBu. |
| Freq. response | : 20 - 20.000 Hz \pm 0,025 dB at 80.000 Hz -3 dB |
| Equalization | : \pm 18 dB at 15.000 Hz shelf (\pm 16 dB at 10 kHz) \pm 12 dB at 1.000 Hz bell \pm 18 dB at 50 Hz shelf (\pm 16 dB at 70 Hz) |
| Overall | : Total harmonic distortion less than 0,039%. Max gain through desk 80 dB incl. postfader gain of 10 dB. |
| Dimensions | : 483 x 95 mm x 400 mm |

Block diagram

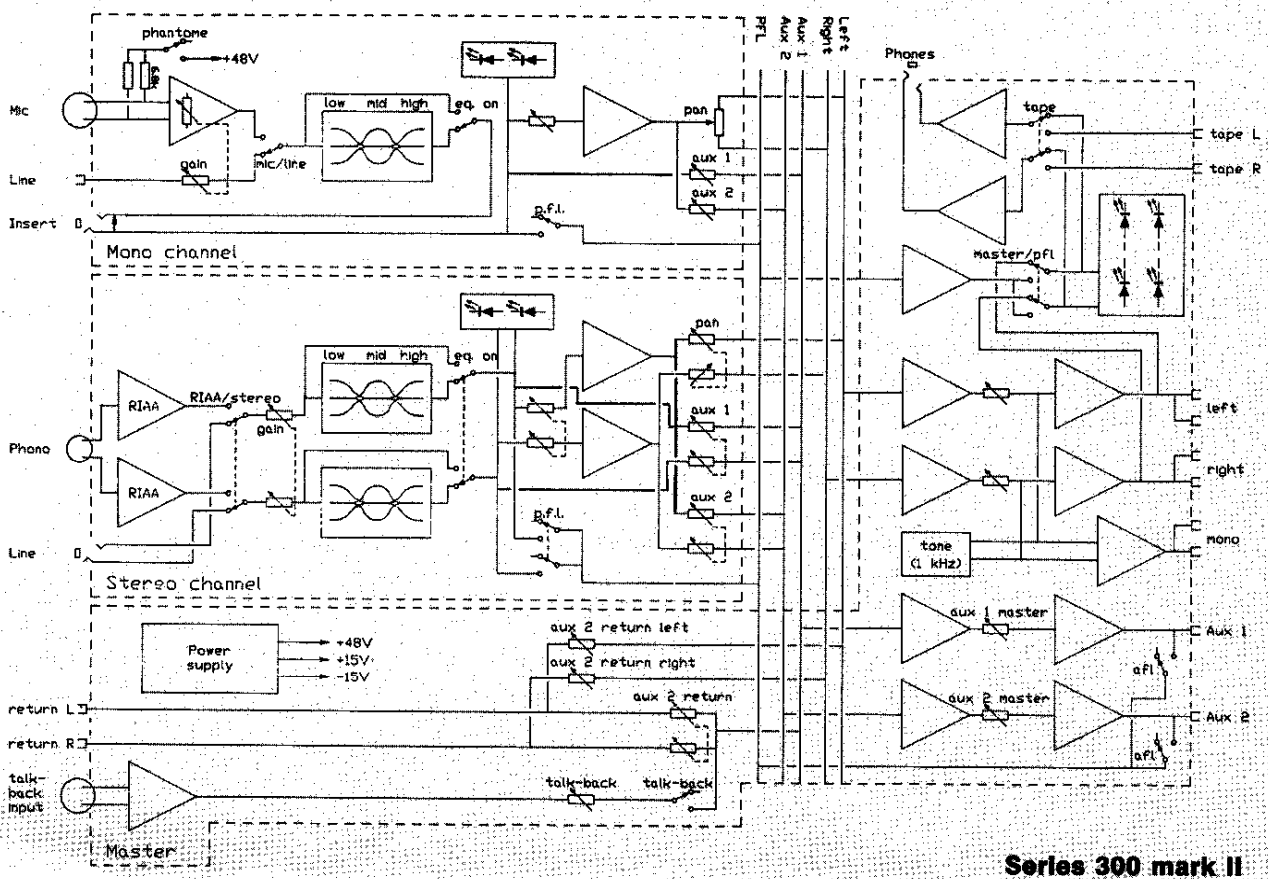

We reserve the right to modify or change designs without prior notice.

