



# POWERVCA

**MANUAL**  
**version 2.18 (beta version)**



<b>1. INTRODUCTION</b>	<b>3</b>
2. <i>Installation</i>	4
2.1. <i>Hardware Installation</i>	4
2.2. <i>Software Installation</i>	5
2.2.1. <i>Installing Smart Drive</i>	6
2.2.2. <i>Making a DOS-flop</i>	6
2.2.3. <i>Example of AUTOEXEC.BAT and CONFIG.SYS</i>	6
3. <i>Getting Started</i>	7
3.1. <i>Introduction</i>	7
3.1.1. <i>Menubar</i>	7
3.1.2. <i>Timecode bar</i>	8
3.1.3. <i>Status bar</i>	8
3.1.4. <i>Mix section</i>	8
3.2. <i>Starting a Mix</i>	9
4. <i>Enhanced Mixing /Editing a Mix</i>	11
4.1. <i>Update in automation</i>	11
4.1.1. <i>Updating fader levels</i>	13
4.1.2. <i>How to update mutes</i>	16
4.2. <i>Using the off-line editor</i>	17
4.2.1. <i>Keyboard shortcuts</i>	17
5. <i>Keyboard shortcuts</i>	18
5.1. <i>Menu</i>	18
5.1.1. <i>File menu (F1 or ALT+F)</i>	18
5.1.2. <i>Set-up menu (F2 or ALT+S)</i>	19
5.1.3. <i>Tape menu (F3 or ALT+P)</i>	20
5.1.4. <i>Group menu (F4 or ALT + G)</i>	21
5.1.5. <i>Help menu (F5 or ALT + H)</i>	21
5.1.6. <i>Display menu (F6 or ALT + D)</i>	21
5.1.7. <i>Edit menu (F7 or ALT + E)</i>	21
6. <i>Trouble shooting (FAQ)</i>	24
7. <i>Contact addresses</i>	27
8. <i>What's new in PowerVCA</i>	28

# 1 INTRODUCTION

Thank you for choosing D&R's PowerVCA Automation software. PowerVCA software gives you automated fader mix-movements on your console. This software package contains a floppy with PowerVCA software, a Music Quest (MQ) Interface (*not necessary with the Octagon console*), communication cable, and a manual.

Installation of this package needs as a minimum PC configuration, a Pentium 2, 233 Mhz 32 Mb internal memory, a free ISA slot, one free IRQ (2/9 or 3 or 5 or 7) and a VGA display adapter.

**Note: There need to be no onboard Soundcard!!**

PowerVCA software requires 1 MB of Harddisk space. Mixfile size depends on the configuration of your console. (9.0 Gb harddisk is optimal)

PowerVCA software was exclusively written for users of D&R consoles. This software can record (write) and play (read) your mix movements to and from your harddisk. As synchronisation with your Music/Video, SMPTE (Timecode) is used. For simplicity you can compare this functionality with a tape deck. Having recorded your mix it may be changed. With PowerVCA software you have the tools to make changes in the mix. But you can only make changes in the mix where there is timecode present. Timecode is precisely linked to recorded audio material and avoids unwanted changes in mix data.

## 2. Installation (not necessary with the Octagon)

Before installation you must know that the software only works fine in MS-DOS. Prevent problems by not running PowerVCA in combination with Windows 3.1, Windows for Workgroups (3.11), Windows 95/98 or Windows NT.

**Be sure you DO NOT use one of these programs at the same time.**

While installing you need an empty floppy-disk . Get one prior to installation of PowerVCA.

### 2.1.

#### . Hardware Installation

Please read the instruction below very carefully

Unpack your music Quest SMPTE card and check the settings on the card

The settings can be found on the Switch S1. See for location picture below:

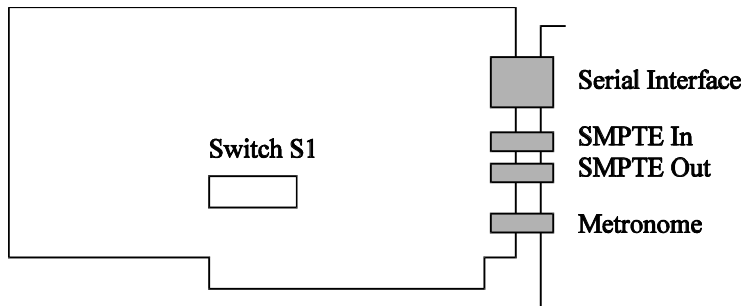

**Note:**

The first 4 switches located in switch S1 need to be positioned in the following way.

- 1=off (down)
- 2=off (down)
- 3=on (up)
- 4=off (down)

The remaining 5/6/7/8 IRQ switches could be changed according to the 4 situations shown on the left side pictures of the S1 switch.

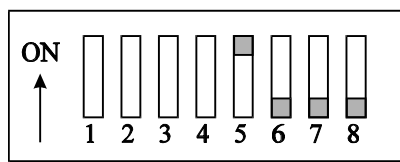

IRQ 2/9

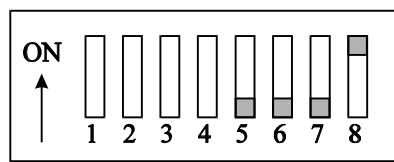

IRQ 3

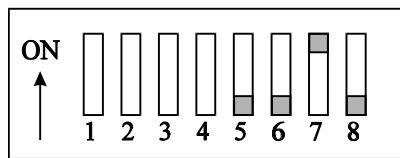

IRQ 5

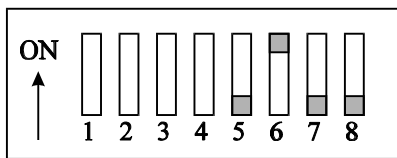

IRQ 7

Default is IRQ 2/9.

The complete default setting should look like:

- 1=off (down)
- 2=off (down)
- 3=on (up)
- 4=off (down)
- 5=on (up)
- 6=off (down)
- 7=off (down)
- 8=off (down)

1. The default settings are IRQ: 2 and address 330. These setting are normally free to use. Only when you have problems you may change these settings. See Chapter Troubleshooting.
2. Turn the power off from your PC and Console and insert the Music Quest Card in an ISA-slot of your Personal Computer. Please follow carefully the instructions from your computer manual.
3. Connect the in and output of the tape track, or other timecode in/output addressed for SMPTE-Timecode, to the Music Quest card
4. Connect the console to the computer, using the enclosed communication cable.
5. Now you have installed the hardware, turn on your console and PC.

## 2.2. Software Installation (**also in case you have an Octagon**)

Now you can install your software.

1. Go to the Dos prompt and type A:<enter>
2. Now insert your PowerVca floppy and type <install> <enter>

PowerVCA will ask some questions which has to be answered very carefully. After the program files are copied you must initialize your start-up sequence. This set-up is needed to be sure you have the following performance and installation:

- \* A fast access to harddisk (use SMARTDRV).
- \* 580 kB of free base memory is required
- \* Operating without Windows (**NOTE: PowerVCA is not running while Windows Operating System is active!!!**).

### 2.2.1 Installing Smart Drive

Smart Drive can be installed using two methods, we prefer the first one. But when you have problems you can also use the second method. The functionality of both installations is the same.

First method uses "AUTOEXEC.BAT" (Dos version 6 or higher is preferred):

```
C:\DOS\SMARTDRV.EXE 2048 1024
```

**Caution:** When SMARTDRV.EXE is located into another directory you can change these into  
C:\DOS\SMARTDRV.EXE 2048 1024

The first number entered after SMARTDRV specifies the size (in kilobytes) of the memory cache in MS-DOS. The second number specifies the size (in kilobytes) of the memory cache when Windows is running.

The first number should be 2048 but when you want to reserve more memory for cache you may increase this number. The second number determines the cache for Windows, PowerVCA doesn't use this number. You can't execute PowerVCA using Windows!

Second method uses "CONFIG.SYS":

```
DEVICE = C:\DOS\SMARTDRV.SYS 2048
```

You will have to adjust the drive and path for your computer when SMARTDRV is located in another directory or on another drive.

The number specifies the size (in kilobytes) of the memory cache. If you have more memory in the computer, you can increase the memory for SMARTDRV. If more memory is specified, larger mixfiles can be saved more quickly. A good ratio between mixfile/cache size is 2:1

### 2.2.2 Making a DOS-flop

You can run DOSFLOP.BAT from your install disk to make a bootable floppy.

This floppy can be used instead of running Windows first. The computer can be started with software from the bootable floppy-disk.

Check the directories of SMARTDRV and your mouse driver. You can eventually change these directories to your custom directory names.

### 2.2.3 Example of AUTOEXEC.BAT and CONFIG.SYS

In the root of your floppy (A:\) you can find two file examples of AUTOEXEC.BAT and CONFIG.SYS. These files give you an idea for your own start-up files.

We also added an ICON and PIF file. You can use these when you want to execute PowerVCA from Windows 95. To do this you must copy Power.PIF from A: to the desktop.

## 3. Getting Started

### 3.1. Introduction

When PowerVCA has been installed correctly, you can start "PowerVCA". This can be achieved by going to [POWER] in the sub directory where PowerVCA has been installed, followed by an <ENTER>.

PowerVCA is now executed and will normally show the screen below. If the Music Quest interface card cannot be found, the software exits with an error code. To solve this problem go to chapter "Troubleshooting".

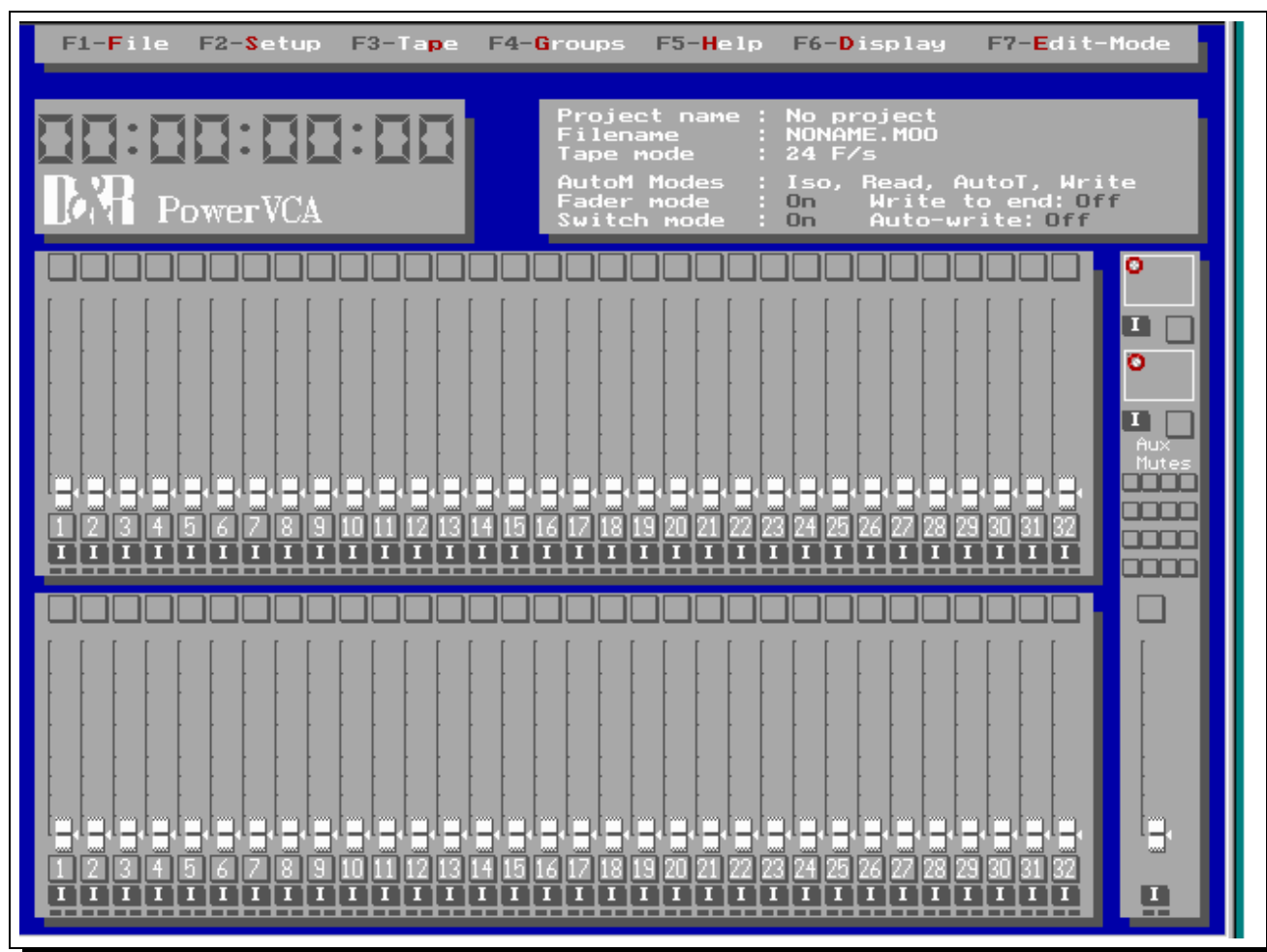

The mix screen is divided into four main sections; Menu bar, Timecode bar, Status bar and the Mix window.

#### 3.1.1 Menu bar

With this bar you have the possibility to access all functions of PowerVCA. You can use a mouse to open several menus. You also can use the keyboard; use the function keys to open a sub menu, for example press [F5] to open the help menu. You can also open the help menu by pressing [ALT + H]. When you are in the help menu you can choose "Help" or "About" topics using the mouse or cursor controls. All other menu's can be accessed in the same way.

### 3.1.2 The Timecode bar

The timecode bar displays the timecode the computer (MQ-card/Octagon) is receiving. When you are in automation mode (Recording and Playback), the timecode screen area displays red. If the timecode display is grey, no mix information will be stored on disk.

**NOTE:**

**!!!It is important that no timecode is generated during fast forward and fast rewind modes! This timecode can messup already recorded automation data. (On an ADAT BRC it can be switched off for example)!!!**

### 3.1.3 The Status bar

**Project name:**

The status bar gives you information about the set-up PowerVCA is using. On the top of the status bar you find the name of the project you are currently working in.

**Filename:**

When the filename is displayed you can see how files are stored on your harddisk. This is useful when you want to manage your mix files with an external manager (e.g. Norton Commander).

**Tape mode:**

The tape mode shows the format of timecode that is activated. The interface will be set-up accordingly to the setting made in this bar.

**AutoM Modes:**

The next line shows how the automation modes activated. The automation mode can be toggled by pressing the SEL switch on the console or by mouse clicks on the screen.

**Fader Mode / Switch mode:**

There is a global fader and switch setting that can have three modes.

- On** The object (fader or switch) can record and playback data.
- Safe** Data may be played back but the object cannot record data
- Off** There is no interaction with this object (no record and playback).

(global means that all the channels are set into the selected mode).

All these setting may be modified by using the menu's. You can also alternate between Tape mode, Automation mode, Fader mode and Switch mode by simply clicking the mouse on the spot.

**Write to end.**

When the tape stops, data of the channels in "Write mode" will be overwritten until the end of the Mix.

**Autowrite.**

When using motorfaders the channel stays in the "Write mode" if the fader is untouched in Autotakeover.



### 3.1.4 The Mix section

This section is used to display all information of the console. It shows the modules (the number is equal to that in your console) and the master (when your console has an automated master section).

The picture on the left gives a section of an module. On top you see a button (MUTE). this button shows the state in which the console mute (of that specific channel) is.

You can change the state by clicking with the mouse or by pressing the mute on the console. Then there is the fader knob which displays the exact position of the console fader (whether it is a VCA or motor type fader. When a fader is configured as a slave or as a group fader the knob will have the selected group colour

. Positioned on the left side of the knob you see a red line. This line is only displayed when a console with VCA faders has been connected to the computer. This line gives an indication of the **actual** VCA level inside the console. The little white triangle on the right is called the memory pointer. This triangle displays the position / level of the VCA's in the mix. When you are recording it shows the **previous** VCA level, so you can fade back to the old VCA level easily.

Direct under the fader the module number is shown of the fader/mute/select. This box shows a related group colour when the fader is a group or master fader. This is selected in the menu "Groups (F4)".

The next button is the Select switch. A mouse click can change this state (depending on your set-up of automation modes). You can also change this state by pressing the knob on the console.

The two little boxes display the local switch and fader modes. Now you can set-up the switches and faders in the module section individually to On, Safe and Off.

The above instructions also applies for the master section. The master fader contains the same elements as the channel faders. Also the mutes are working like channel mutes.

### 3.2. Start Mixing

After this introduction you are ready for the real thing.

First check if your console is powered up and turn on your computer and start PowerVCA.

Press F5 and see what console type PowerVCA has installed. When these settings are wrong try to reinstall PowerVCA and be sure to properly answer the questions of the installation program!

Use the escape key or right mouse button to exit to the main screen.

Now you're ready to start your first (new) mix.

Your first activity, when starting a new mix, is to choose the item "create dir" to create a new "work/project" directory. Now select "NEW" from the file menu and select the right directory and press <ENTER>. Type here the filename of your mix. When the name already exists an error alert comes up and asks you to change the name.

In the menu set-up you can change the number of backups. This determines how many old mixes (of the current project) will stay on the harddisk. The backup number is saved in the extension; M01, M02, M03 etc. The highest number is the latest mix.

**WARNING:** you can have a maximum of 100 backups. **Never** use the backups like safety backups. Save or copy your mixes with another name to a floppy for safety backups. When your mix files are greater than 1.44 MB they don't fit on a floppy. The files should be compressed with a compression program like PKZIP, RAR or ARJ. Ask your local computer dealer for more information.

How to use PowerVCA with file management?

PowerVCA works with normal MS-DOS files. These files may be copied and moved using a DOS file manager.

How to set-up the management system?

When you start a project make a directory for that project (in menu "File - Create Dir"). All your mixes and backups/undo's of the specific project should be saved in the new directory.

In the SMPTE menu you must set-up the Time Code format you are working with. This is a very **important** item because you could lose some valuable information. You can choose out of 24, 25, 30 frames and 30 drop frame.

You also can set-up your global switch and fader modes. The modes you can use are:

**On,** record and playback allowed.      **Safe,** record not allowed and playback only.

**Off,** record and playback not allowed. (For your first mix On and Safe should be active).

After this whole set-up you can begin with your mix.

PowerVCA has been designed to work fast, when mixing it is never necessary to leave the main screen!

First press the shortcut ALT + W to set all modules into the automation mode called WRITE.

This mode is used to write a new mix or overwrite existing mixdata. The next step is to set the fader and mutes to their initial values. When timecode runs PowerVCA responds and locks into automation. The area in which timecode is displayed changes into red when locked in. When this does not happen please go to chapter "Trouble shooting".

The initial fader and mute positions are saved and while timecode is running you can change fader positions and switch mute's on and off

Now stop the tape and the following message will be shown in a question box. Answer "YES" to save all fader and mute changes, now the version number will be updated and you will return to the main screen. The select switches turn automatically to READ (for safety). When the timecode is started again (after rewind) the mix is played back. When the Select switches are in Read mode you cannot record anything. This is the procedure to start with a mix. To further adjust this mix will be explained in the next chapter.

The picture below gives an example of a simple mix and is used as an example in the next chapter

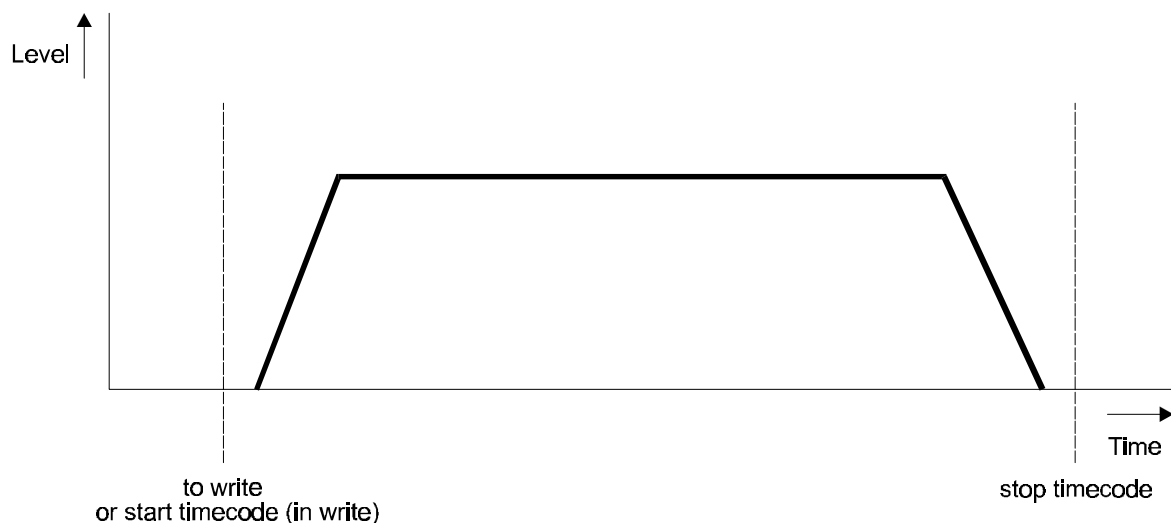

- Recorded mix data
- Previous mix data
- ..... Release

Legenda used in the diagrams

## 4 Enhanced Mixing / Editing a Mix

After you have made your first mix, you can improve and correct your mix of course.

There are two methods to do this.

- \* You can edit the mix while in automation mode with time code running (dropping in your new movements)
- \* You can use the off-line editor. This editor gives you an event list where you can change events.

### 4.1. Update in automation

When you have recorded your first mix, you can correct your mix while its played back. There for D&R has developed a simple and efficient software program. With the Select switch you can choose how the software handles the data. This Select switch determines the automation mode of one channel. This include Mutes and Faders at the same time. There are several modes to choose from which will be shown below.

**ISO** No automation will be used, either in playback (read) and record (write).  
The select box is grey with an 'I' inside.

**READ** Mutes: PowerVCA can only playback recorded data  
Faders: PowerVCA can only playback recorded data  
The select box is green with an 'R' inside.

**AUTOTAKEOVER** Mutes: PowerVCA can only playback recorded data  
Faders: Fader moves are played back until you touch the motor fader.  
when the fader has been touched the new fader move will be recorded.  
For VCA-faders PowerVCA writes data when you match the Fader knob with the VCA-line / Memory pointer.

AUTOTAKEOVER consists of two sub modes, Read and Write.  
with VCA Faders you can toggle from AUTO-write to AUTO-read with your select button.

Motorfaders exit the sub mode Write when the faders are untouched.

In AUTO-write the select box on the screen is coloured red with an 'A' inside.  
In AUTO-read the select box on the screen is coloured blue with an 'A' inside.

**WRITE** Mutes: The actual value overwrites the old value in the mix.  
Faders: The current fader position overwrites the old one.

**WARNING:** When you drop in with WRITE the old value shall be overwritten! This can give an jump in your audio!  
The select box is red with a 'W' inside.

<b>TRIM</b>	Mutes:	Mutes will be recorded.
	Faders:	In this mode you can give an offset to the fader envelope. Motorfaders get there offset from the point you touch them. VCA-faders calculate the offset depending on the current position and the position when the TRIM mode has been entered. The select box is yellow with an 'T' inside.

Its also possibly to activate the Select button for one or more Mutes or Faders. Use the global switch or fader status.

When your faders are in the following modes you can expect the action shown below.

- On** Faders act normal.
- Safe** Faders are switched into playback-mode
- Off** Faders do not work (are in ISO).

If the switches are set in these three modes you can expect the following behaviour.

- On** Switches act normal
- Safe** Switches will follow saved mix (playback).
- Off** Switches do not work (are in ISO).

You can choose in which operating mode you like to mix.

In the next chapter we give an example of how to update your mix.

### **Write to end**

The write to end function writes the current data until the end of a mix and the tape stops.

This only happens for those channels that are in the "Write" or "Auto-write" mode at that moment.

### **Auto-write**

The Auto-write function prevents the fader of having a release when the motorfader is untouched.

The fader stays in the "Write" mode until the tape stops or the Select switch is pressed.

#### *4.1.1 Updating Fader levels*

Before updating faders be sure that the switches are in the Off or Safe mode. Now your switch (mute) data will not be affected. Before updating we should have a look at the automation mode sequence. This sequence determines which mode would be most likely to follow the current mode you are in. First we have a look to the "READ - WRITE" sequence. The WRITE mode can be used to overwrite data of the old mix.

We start with the basic mix, recorded in the previous chapter. You have to place all the faders in Read (ALT + R); start Timecode (before the point of requested change). When you reach the timecode position where an update is necessary, press the Select button of the channel. Now the channel switches to the Write mode and all data will be overwritten until the tape is stopped or the Select button is pressed again. When you press that button your are going back to Read mode and the fader position returns to the old mix position within a (user definable) release time.

See picture:

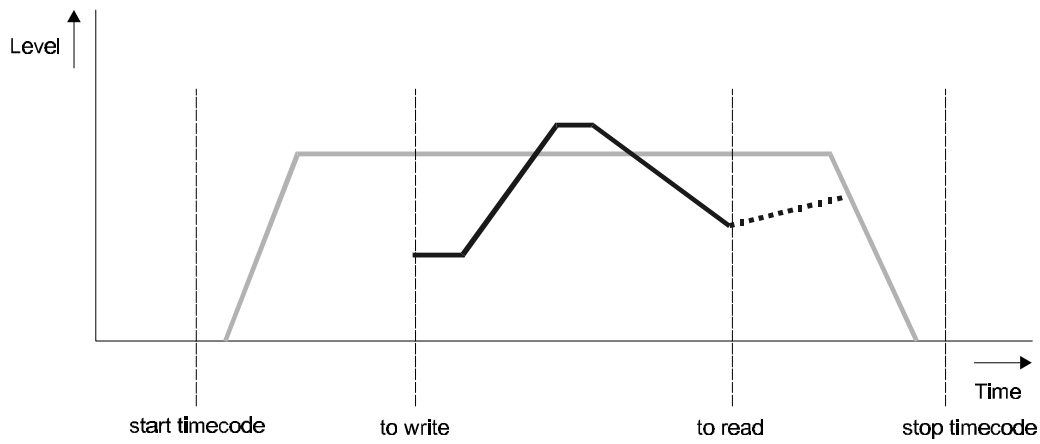

Results of an update:

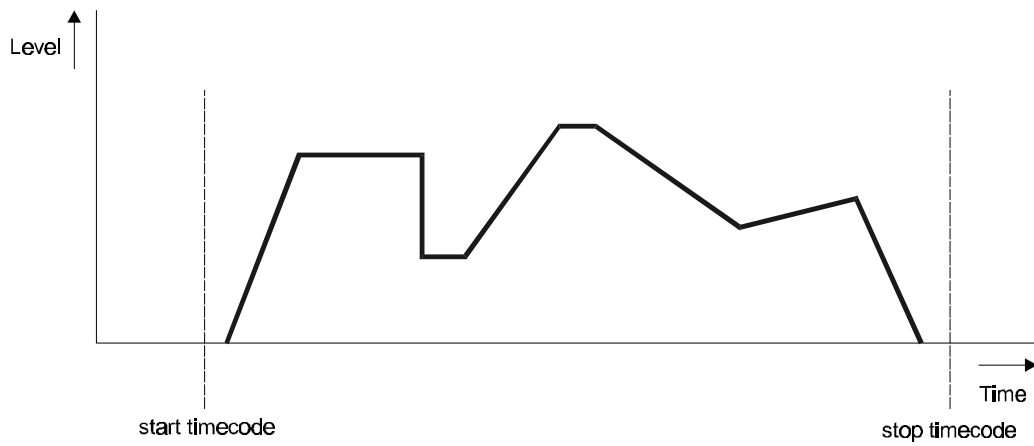

- Recorded mix data
- Previous mix data
- ..... Release

Let's take a look at the "READ - AUTOTAKE OVER" sequence.

The AUTOTAKEOVER mode can be used to write data over the old mix data without using the Select button, this mode is usually used with *motorfaders*.

Let's start:

We use the first mix out of section 3.2. Place all faders in Auto (ALT + A); and start Timecode. Both Select LED's are on now. When you want to change some fader movements touch the motorfader and the green Select LED turns off and you are in record (write) mode. Now your movements are recorded until you stop the tape or lift your fingers from the motor fader knob. After returning to Read the faders will return to the previous mix position (if exists) with a user definable speed.

When using **VCA faders** the same performance will be shown in "AUTO - write" now you should match the fader knob and VCA/Memorypointer position before auto-write will be activated. To exit the "AUTO - write" simply press the select button. the VCA also return with a release time.

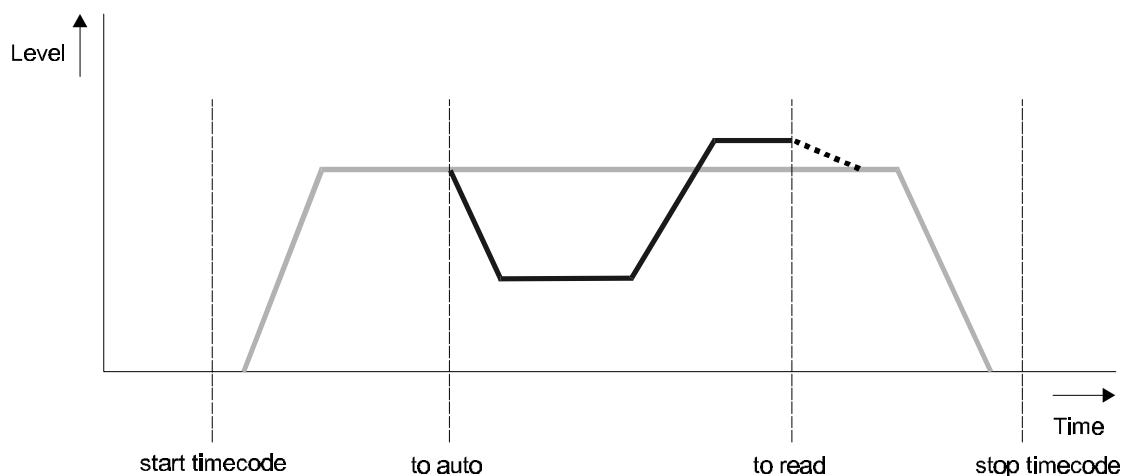

First mix:

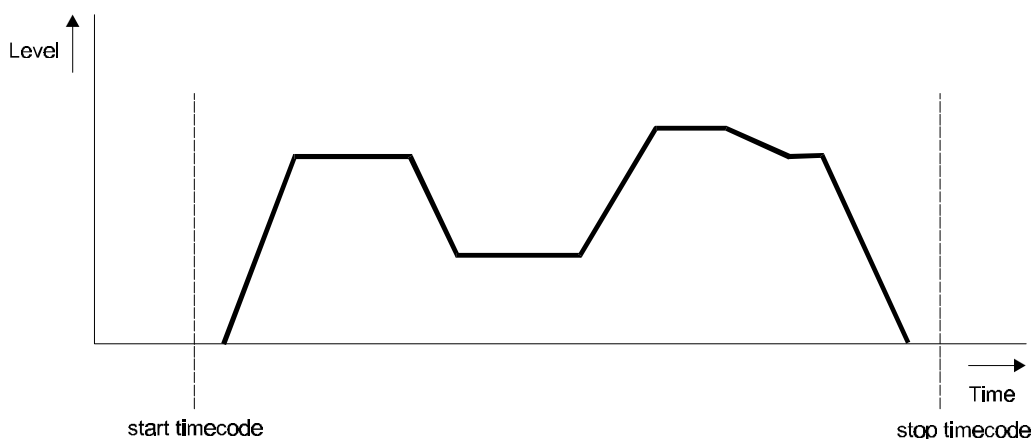

First mix after AUTOTAKEOVER sequence.

- Recorded mix data
- Previous mix data
- ..... Release

Now we shall have a look at the "READ - TRIM" sequence. The TRIM mode can be used to trim data of the previous mix.

How to use this method?

Place all faders in TRIM (ALT + T); and start Timecode. When you want to change some fader movements touch the motorfader. Trim mode with a motorfader causes a selected offset to be calculated through the whole mix up to the end of the recording. The end of the recording is when you leave TRIM by pressing the Select button (a fader release is introduced (user definable) in relation to the old fader data). You can also stop the tape. Only when the "Total Trim" option is active the offset is calculated to the end of the mix.

With VCA faders the offset you give is relative to the fader position at the start of the TRIM mode (Fader position when you enter the Trim mode). The relative dB value is added to the current memory (pointer) position.

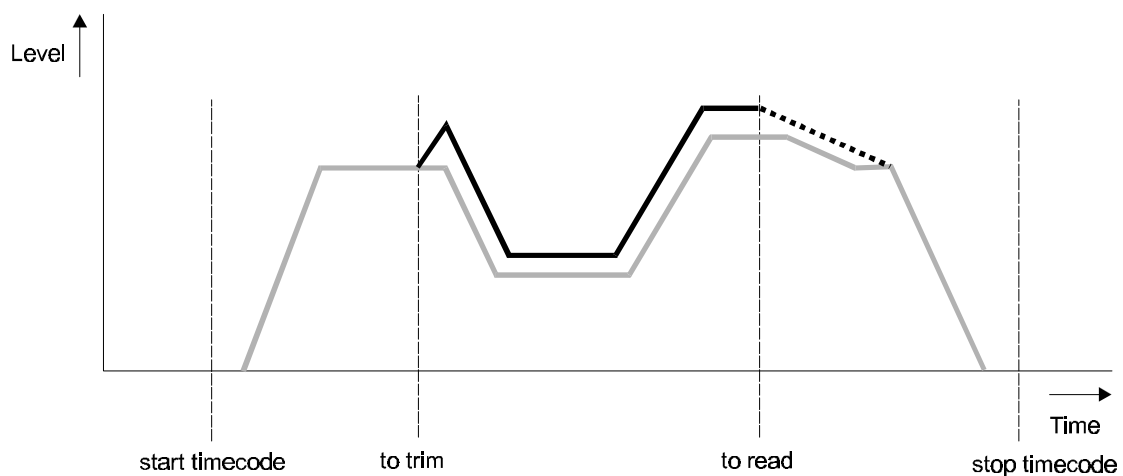

First mix

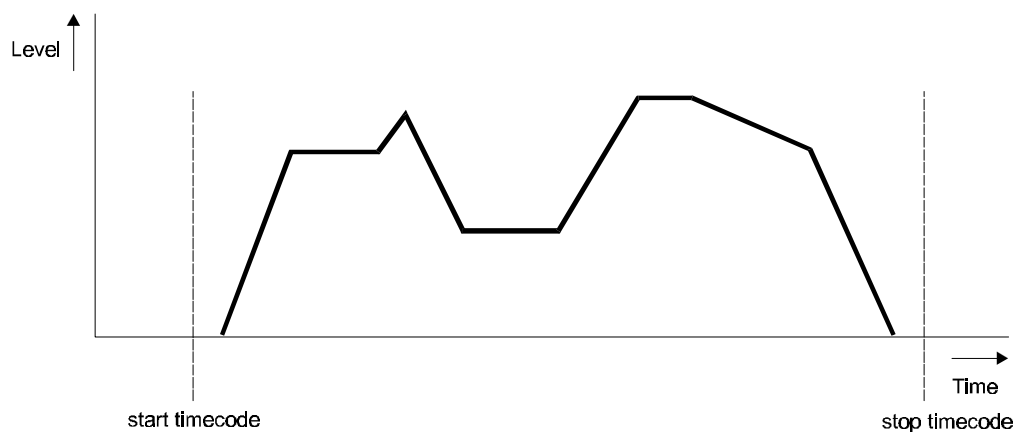

Result after Trim mode.

- Recorded mix data
- Previous mix data
- ..... Release

### 4.1.2 How to update Mutes

Before updating mutes be sure that the faders are in the Safe or Off status. Mostly used is the Safe mode, so faders are in playback (Read) and not in record (Write)

The mutes can only be updated in the WRITE and TRIM mode because in all other modes Mutes will be in READ mode. It is therefore that it is wise to use the automation mode sequence for Mutes to be "READ - WRITE". This can be found on the status bar or in the menu 'F2 - SET-UP -> AUTOM MODE".

Before starting timecode put all of your channels in READ by pressing ALT + R, then start timecode. While timecode is running the mix is read. But from the moment you want to update/change a mute, you first must press the Select button and then you go to WRITE mode (because the automation mode sequence is "READ - WRITE"). Now you can program your mutes by simply pressing the mute switches. To stop the Mute programming press the Select button or stop the tape. Note: only data will be written related to timecode that have been shown on your screen previously!

Here below you see three figures which give an impression of what's happening while updating mutes.

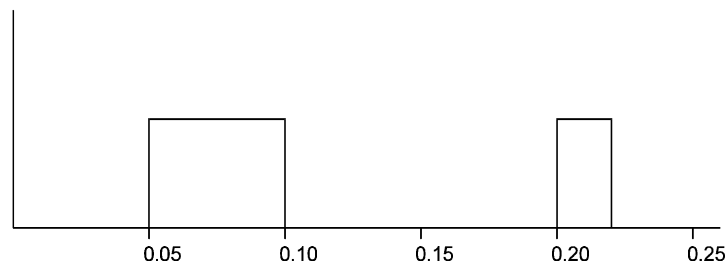

Fig. 1

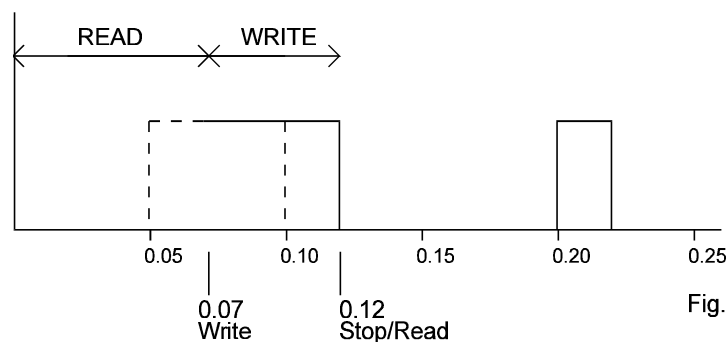

Fig. 2

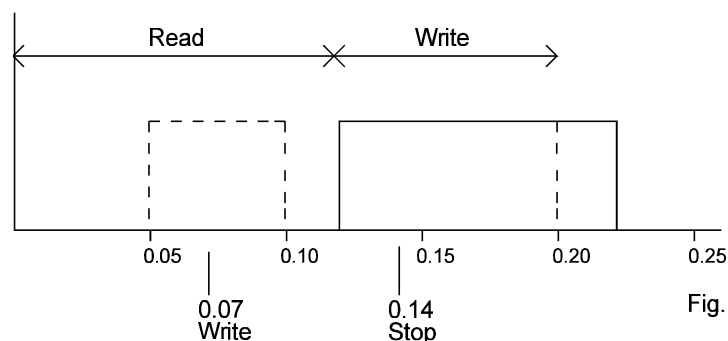

Fig. 3

## 4.2. Using the off-line editor

The Off-line editor is an external program written to change mix data (PWR\_EDIT.EXE).

When the program has been started an event list is displayed. This list may be changed by adding and deleting events.

In the first menu you have the options Save and Exit. Save is used to save the new mix and Exit to return to the PowerVCA program.

The next menu "Search" gives the possibility to search for a specific timecode or the start/end of a mix. You only have to enter the timecode in the format hours, minutes, seconds, frames.

In the item "Filter" you can make filter settings. With your keyboards "spacebar" you can change the filter setting pro channel and pro item such as Master Fader, Mute, Aux Mutes, Inserts, Master mute. When an "X" is display the item will be shown in de event list. or else this item isn't displayed.

The last menu is Edit. This menu can be used to add/delete data. The topic Undo in the menu "Edit" can be used to restore the last action.

The next topic "Add" shows a dialogue box. In this box you can add data to insert into the mix.

The "Delete" topic enables you to delete events. With the option modify its possible to change events.

The last option in the "Edit" menu is Trim. You can use this option to give an relative trim (e.g. +10dB) on an range of events. You may enter a start and end timecode, the offset is calculated within the timecode range.

### 4.2.1 Keyboard shortcuts

Alt-F	File menu
Alt-S	Search Menu
Alt-I	Filter Menu
Alt-E	Edit Menu
Alt-X	Exit
Alt-Backspace	Undo
Insert	Add event
Delete	Delete event
Alt-M	Modify event

## 5.0 KEYBOARD SHORT CUTS

### 5.1. Menu

<b>F1</b>	File	This sub menu lets you manipulate getting and saving of mixes
<b>F2</b>	Set-up	Defining parameters of PowerVCA such as the number of back-ups
<b>F3</b>	Tape	Formatting (striping) of tape
<b>F4</b>	Groups	Creating, deleting or changing group masters and slaves
<b>F5</b>	Help	Information about software and the written manual
<b>F6</b>	Display	Changing back ground colour schemes to personal taste
<b>F7</b>	Edit mode	Changing channels individually or globally into another mode (Read, Write etc.)
<b>Alt-X</b>	Quit	
<b>Alt-R</b>	All channel into READ mode	
<b>Alt-W</b>	All channels into Write mode	
<b>Alt-A</b>	All channels into Auto Take over mode (AutoT)	
<b>Alt-I</b>	All channel into Iso mode	
<b>F9</b>	Open file	
<b>CTRL-U</b>	Undo	

#### 5.1.1 File menu (F1 or ALT+F)

**Open/Del (F9)** This menu lets you retrieve or delete a stored mix from hard disk

**New** This menu lets you create a new filename. The software will ask for the project name to keep a well organised hard disk.

**Save (Config)** In this menu you save the configuration in the work directory of PowerVCA . Everytime a new mix is made this configuration will be used!

**Save as** In this menu you can save mixes to other directories (floppies) then the PowerVCA work directory. You can also choose to save from start or the current position.

**Create Dir...** In this menu you can create a directory to store more mix files.

**Edit** This menu is for Off-line editing of a mix file.

**Quit** (Alt-X) use this menu to quit from PowerVCA correctly

**UNDO** Opens the previous mix and deletes the current mix.

### 5.1.2 Set-up menu (F2 or ALT+S)

**BACKUPS** In this menu you decide how many backups of your mixes will be stored onto hard disk.

Page up (Pg Up) and Page down (Pg Dn) lets you set a number between 1 and 99.  
The Enter key enters the chosen information onto PowerVCA's hard disk.

**LABELS** Information with a maximum of 40 characters can be typed for every channel fader.  
Use Page up and Page down to move to the next page.  
Use Alt-P to print the information. PowerVCA sends it information to LPT1 first.  
If your printer is not hooked up to LPT1 it asks for LPT2.

#### SET-UP RELEASE

Set-up release.

When a channel changes from "WRITE" into "READ" (WRITE>READ, TRIM>READ),

the VCA-level and Mute will go back to their old value. (The mem-pointer for the VCA-level).

With "Release" you select the number of frames the fader (VCA) needs to go back to its old level. The range is set from 1- 255 frames.

Note: The VCA 's or mutes will go back to their old value if there is old mix-data.

When you start a new mix, and a channel goes out of the "write" mode, it holds the position from that moment. (See "Make changes in you mix").

Set-up Total Trim.

When you trim a channel, let's say 3dB, and you stop the tape, the channel normally goes back to the old value (in the mix) at the moment you have stopped the tape.

When Total Trim is On, and you have trimmed a channel with 3 dB, the moment you have stopped the tape, the offset of 3dB will be on that channel for the entire mix.

This is also true for mutes. When you stop the tape, the mute will go back (in the mix) to the old level. When Total Trim is On, the mute keeps its value until the end of the mix, or when a change occurs in the mix.

**SMPTE** Here you can change the number of frames per second. (24,25,30D,30 Frames)

***NOTE: PowerVCA reads all frames, but can only generate 30+30D at this moment.***

**FADERS** This menu lets you decide if you want to store fader movements (ON) or just want them to be replayed only (SAFE), or not doing anything at all (OFF).

You can also change the fadermode by pressing the left mouse button on the "fader-mode" in the info box on the top right side of the screen

**SWITCHES** This menu is exactly the same as the faders menu. This menu lets you decide if you want to store switch settings (ON) or just want them to be replayed only (SAFE) or not doing anything at all (OFF). You can also change the switch mode by pressing the left mouse button on "switch mode" in the info-box on the top right side of the screen.

## AUTOMODES

This menu shows the status in which the channels can be set. There is a choice out of 6 combinations that will be active in that specific order by depressing the select switch in the channels

1. **ISO, Read, AutoTake over, Write**
2. **ISO, Read**
3. **ISO, Read, AutoTake over**
4. **Read, AutoTake over**
5. **Read, AutoTake over, Write**
6. **Read, Write**
7. **Read, Trim**

To select one of the modes use the Page up and Page down keys. You can also change the Automodes by pressing the left mouse button on "Auto Modes".

**AUTOSAVE** If autoSave is active (On/Off) PowerVCA stops asking you after every mix if you want to Store your mix with "yes or no". (Y/N) (on your keyboard Y or N ) In cases where the filename already exists PowerVCA will ask for another file name.

**MOUSE** In this menu you set the mouse speed.

**CLEAN UP** Not used

**WRITE TO END** Overwrite data until end of mix.

**AUTO-WRITE** Stays in write after after Auto-mode+untouching the fader

**Comm-port** For Octagon only to select a communication comm-port.

### 5.1.3 Tape menu (F3 or ALT+P)

#### **STRIPE TAPE** (Not necessary with the Octagon)

To synchronise PowerVCA with a multitrack tape it is essential that there is information on that tape that PowerVCA can identify. We have chosen for the world standard SMPTE timecode.

Before beginning any form of automation it is necessary to format (or stripe) the tape first. The Music Quest card has 2 cinch connectors for reading and writing SMPTE codes. Please use a corner track of your multitrack or a special timecode track of your machine Page up and down lets you choose between timecode format writing.

It is good practise to record about -20 below maximum tape input level.

**NOTE: At the moment PowerVCA only generates 30 and 30 D frames, but it can read all other time codes such as 24, 25, 30, 30D.**

The arrow keys lets you move from one position to the other to enter the start time by using the Page up (Pg Up) and Page down (Pg Dn) keys.

NOTE: Always start with 1 hour to begin with, to avoid negative time code when rewinding too far.

**DROP OUT** In this menu you decide how many frames will be generated automatically when there is a drop out.

#### 5.1.4 Group menu (F4 or ALT + G)

##### F4 (ALT-G) GROUPS

**Masters** This menu lets you choose your master faders. The arrow keys choose the master fader and the TAB key lets you move to the next screen showing fader 33 and higher. Click with the left mouse button on ">>" to go to the next screen. There are 8 group masters available, all 8 are displayed on the left top side of the sub menu screen. Choose a number between 1 and 8. Remove masters with the spacebar. The unused master faders are shown top left on the screen.  
*Cr= accepts settings, then exits.*  
*Esc=cancel, exit.*

**Slaves** This menu lets you create slaves for a specific master fader. All chosen master faders are displayed. The Tab key lets you move to the next screen, or click with the mouse button on ">>" to go to the next screen. A slave is selected by the arrow keys and coupled to the master by one of the numbers 1 to 8 as selected earlier in the masters menu. The slaves will get the same colour as the master. To erase a slave use the spacebar.  
*Cr=accept settings, then exits.*  
*Esc=cancel, exit.*

#### 5.1.5 Help menu (F5 or ALT + H)

**About** Gives information about console type, number of modules, software version etc.

**Help** on-line information.

#### 5.1.6 Display menu (F6 or ALT + D)

**Colours** The background colour can be changed by using the Page up and Page down keys.

**Display** This menu lets you choose which fader section will be shown on the screen. Use the Tab key to go to the next screen and shift-Tab to go back.

- |    |       |          |
|----|-------|----------|
| 1. | 1-32  | Chan+Mix |
| 2. | 33-64 | Chan+Mix |
| 3. | 1-32  | Chan     |
| 4. | 33-64 | Can      |
| 5. | 1-32  | Mix      |
| 6. | 33-64 | Mix      |

**Master** This menu lets you choose whether you want to display the master fader or not. A not shown master fader will always be active in the automation sequences.

### 5.1.7 Edit menu (F7 or ALT + E)

This menu lets you change the individual modes of a channel. Every channel can be put into Read, Write, Autotakeover (AutoT) , or Iso mode individually.

Select a channel with the arrow keys and change the mode with the Page up or Page down keys.

All selections in all the menus use the ENTER key to confirm and the ESC key to cancel and leave the screen.

To Change the Automation mode of one channel:

Click with the left mouse button on the automation mode of that specific channel.

To change the fader- or Switch-mode of one channel.

Click with the left mouse button on the indicators under the automation mode.

## POWER-EDIT

Start the off-line editor from the PowerVCA software. (File - Edit)

When a mix file was opened in PowerVCA the screen shows the timecodes with the events.

You can scroll with the up and down keys or Pg Up and Pg Dn or use the mouse (click with left button to select a timecode) .To scroll with the mouse click on the upper and lower horizontal lines.At the top of the screen you see the following commands :

Filter, Edit, Search, File These menu's have the following sub menu's

<b>ALT-I</b>	Filter - Set-up Filter
<b>ALT-E</b>	Edit - Undo, Add, Delete, Modify
<b>ALT-S</b>	Search - Time Code, Start of mix, End of mix
<b>ALT-F</b>	File - Save, Exit
<b>ALT-X</b>	Exit - exit without save

### Set-up Filter

This menu allows you to put some channels or events on or off. At the top of the screen you see the channels. When an 'X' is placed at the channel number, the data of that channel will be shown. Select a channel with cursor keys or mouse. Toggle its value with the spacebar or left mouse button.

You can also select what you wish to see. If you only want to see the fader movements, select it. the same goes for the master fader, mutes etc

### Edit-Undo (ALT-Backspace)

Undo the previous editor action

### Edit-Add (Ins)

Select if you want to add a Fader move, Mute, Aux mute etc.

**Edit-Add-Fadermove**

Fill in the timecode where the fader move has to start. Select the Channel or Mix (toggle with spacebar or mouse button) and number. Value gives the value of the fader at the point where the fader move starts.

Fill in "End" the dB-value the fader move has to end. Fill in "Length" the length of the fader move (seconds)

**Edit\_Add\_Mute**

Fill in the timecode where a Mute has to be active. Fill in, channel or mix (toggle with spacebar) and number. Fill in "Mute" Yes or No to put a mute on or off.

When playing a mute ON, and the mute was already on, the second mute will not be displayed, because it was already on and only changes are displayed.

**Edit-Add-MasterMute**

This is the same as Add-mute. Now you cannot select a channel or mix, but an Aux number and Left or Right

**Edit-Delete (Del)**

Deletes the event you selected

**Edit-Modify**

Modifies the Fader value (dB) or modifies mutes (On > Off etc.)

**F7 EDIT****Search Timecode**

Fill in the timecode you are looking for. The editor will search for that specific timecode, or when it does not exist, the next or previous one.

**Search Start of mix**

Goes to the beginning of the mix

**Search End of mix**

Goes to the end of the mix

**File-Save**

Stores the mix file on disk. If the filename exists a new filename shall be asked for.

**File-Exit**

To exit the off-line editor correctly. You return to PowerVCA automatically. PowerVCA opens the latest saved version of the mix file you have saved in the editor.

---

## 6. Trouble shouting (FAQ)

*PowerVCA doesn't start or works unstable:*

1. Be sure you don't run PowerVCA under Windows, Window 95, Windows NT.  
You can make for example a DOS-floppy to start into REAL MS-DOS.  
When the computer is only used for PowerVCA set your autoexec.bat and config.sys file to start only MS-DOS.
2. Arrange more free (600kB) base memory. Use DOS program "mem.exe" to check this.
3. Also check if there is time code generated while rewinding or fast forwarding, this option should be turned off. (for instance in the big remote of the ADAT's)

*When I start PowerVCA, a wrong console configuration will be displayed:*

1. Be sure the PowerVCA application is started after the console has been powered up.
2. Reinstall the software, be sure you choose the right settings while installing.
3. When the first two points are correct and the problem isn't solved try to delete the file NONAME.M00 (located in your Power directory).

*No timecode is running in the main window:*

1. Restart PowerVCA and try it again.
2. Check the connections from your SMPTE-device to the computer (interface). It should be connected to the SMPTE-in cinch connector.
3. Check the IRQ and Address setting on your Music Quest Interface card . (See chapter installation) (not in case you have the Octagon)

*Grey timecode display*

1. Retry
2. Harddisk is full

*When I move a fader on the console nothing happens on the screen:*

1. Check you MIDI/interface connection. (not applicable for the Octagon)  
MIDI-Out should be connected to MIDI-In, and MIDI-In should be connected to MIDI-Out  
If your console has a sub D connector, it can only be connected in one way.
  2. Check if timecode is running when timecode is sent to the Music Quest card in your PC.  
When Timecode isn't running you must check the IRQ and Address settings of the interface (See Installation) (not applicable for the Octagon)
  3. You can also try the communication in the other direction by pressing ALT-W or ALT-R on the keyboard. when the Status LED's changes the connection to the console is correct.
  4. Probably your cable is broken.
-

*When I playback a Mix nothing happens in the console:*

1. Check your MIDI/interface connection.  
MIDI-Out should be connected to MIDI-In and MIDI-In should be connected to MIDI-Out a SUB-D connector can only be connected in one way. (Not applicable for the Octagon)
2. Check if timecode is running when timecode is connected to the Music Quest card in your PC. When timecode isn't running you must check the IRQ and Address settings of the interface (See Installation) (not applicable for the Octagon)
3. You can also try the communication in the other direction by moving a Fader. When this movement is displayed on the screen the communication from console to computer is correct. Properly your cable is broken.

*The fader movements are jumping up and down when in playback:*

1. Check your SMPTE-Timecode setting, when playing an 30 frame mix with 25 frame timecode the last five frames will be skipped.
2. ***Also check if there is time code is generated while rewinding or fast forwarding, this option should be turned off. (for instance in the big remote of the ADAT's)***

*My select button don't respond correctly, I always stay in the READ mode):*

1. Reinstall the PowerVCA software and answer the Question "Console is manufactured before 1 Nov. 1996" to Yes.

## **7. Contact address**

### **D&R Electronica Weesp b.v.**

Rijkade 15B

1382 GS WEESP-The Netherlands

Phone: ++31 (294) 418014

Fax: ++31 (294) 416987

Webpage: <http://www.d-r.nl> (download your latest PowerVCA software version)

E-mail: [info@d-r.nl](mailto:info@d-r.nl) (we appreciate your comments on our software)

## 8. What's new!

Thank you for using this new version of PowerVCA, version 2.15 gives you an incredible performance. The new features are described in this file.

\* **Fast locking to timecode.**

A little trick enhanced this feature about 10x for large mix-files.

\* **Text to save a mix has been changed to:**

'Store mix on disk? Yes/No'

\* **Trim mode**

The trim mode is working with a higher resolution (steps of 0.2 dB).

**Groups**

\* The group feature is now really dB-relative we even have increased its resolution.

Note: The group feature may be used in all automation-modes (READ, WRITE etc.) a known phenomenon arises when the motorfader slaves are in de ISO or WRITE mode. A motorfader in WRITE or ISO can't be positioned by the PC. In the group feature the PC tries to position the motorfaders in all modes. This gives strange effects. The audio which also is send by the PC will follow the group-master exactly in all modes, so its only a visual phenomenon. In certain Mix-modes you want to record only a group-master move, the slaves are relative, so when using the new group feature take care your slaves are in READ/AUTOTAKEOVER / TRIM and your group master is working in WRITE/ISO or AUTOTAKEOVER. This phenomenon didn't exist when using VCA-faders.

\* **Mouse support fixed.**

No more Grey strings or hanging PC when using the mouse.

\* **Mouse control under automation.**

This feature is very valuable for people using the low-budget automation.

**Faster Saving**

\* The Save procedure (leaving the automation mode) has been optimised to give you the opportunity to record repeatedly on the same time codes.

### 2.18

\* **Write to end**

\* **Auto write**

\* **Octadump is implemented within Powerfade**

\* **Undo**

\* **Save as from current Timecode position**

\* **Windows Pif file**

## Bugs Fixed in PowerVCA 2.11

- \* Save does not crash after "Create Dir...."
- \* Save does not crash with F10 or Cleanup
- \* Store Mix question can be answered with 'y','Y','n','N'
- \* VCA Group slave can be repositioned without loss of data.

## Bugs Fixed in PowerVCA 2.12

- \* Mouse disappears while cleanup is fixed
- \* Data of first frames (snapshot) are no longer lost when recording in write
- \* Spaces in filenames disabled.

## Bugs Fixed in PowerVCA 2.13

- \* Orion background is repaired.
- \* Load function does not crash anymore.
- \* CopyFrom/CopyTo/Open functions do not have a display error (coloured pixels).

## Bugs Fixed in PowerVCA 2.14

- \* Group function has been rewritten.
- \* It is now possible to automate group movements without touching slave data.
- \* VCA channels that are connected to the "high"CPU board are now behaving correctly when going out of the Autotakeover-"write" mode.
- \* The display of the help file is corrected.
- \* Overwriting an already existing file of 8 characters, after writing , with another file name will not cause any problem anymore

## Bugs Fixed in PowerVCA 2.15

(February 20, 1998)

- \* When a mix is saved the correct Tape setup (no of frames) is now saved correctly.
- \* A beep occurring after saving a mix is removed
- \* The joystick select switches are now active again!

## Bugs Fixed in PowerVCA 2.16

- \* Function group auto

## **Bugs Fixed in PowerVCA 2.17**

- \* Less memory space is used.
- \* SMPTE reading more stable now.































































